

LK17 系列

LK17 Series

使用注意事项:

CAUTIONS:

1. 此系列有3种不同硬度的弹性体, 不同硬度弹性体允许扭矩及吸收偏差不同, 选用时请注意。
2. 请务必遵守偏心, 偏角, 轴向的允许公差。
3. 螺栓类请务必以指定的扭矩拧紧。
4. 使用环境范围见下面弹性体参数表。弹性体虽具备耐水性和耐油性, 但极度粘附的环境也会导致产品劣化, 请避免此类情况。
5. 插入安装轴前, 请勿拧紧夹紧螺栓或者加压螺栓。

1. There are three kinds of elastomers with different hardness in this series. The allowable torque and absorption deviation of elastomers with different hardness are different. Please pay attention to the selection.
2. Be sure to observe allowable tolerances of eccentricity, deflection and axis.
3. Bolts must be tightened with specified torque.
4. The scope of use is shown in the following table of elastomer parameters. Elastomers have water and oil resistance, but the environment of extreme adhesion can also lead to deterioration of products, please avoid such situations.
5. Do not tighten clamping bolts or pressure bolts before inserting them into the installation shaft.

安装方式:

INSTALLATION:

1. 确认联轴器的夹紧螺栓有无松动, 去除轴及联轴器内径面的锈迹, 灰尘及油等。特别是, 对联轴器摩擦系数有显著影响的各类润滑脂, 绝不可有粘附, 安装前, 请把轴, 孔清理干净。

Confirm whether the clamping bolt of the coupling is loose or not, remove rust, dust and oil on the inner surface of the shaft and coupling. Especially, all kinds of grease that have significant influence on the friction coefficient of the coupling must not be adhered. Clean the shaft and hole before installation.

2. 请将联轴器插入电动机轴。插入长度必须接近联轴器的边节长度, 使夹紧端面跟轴有足够大接触面, 保证足够摩擦力。

Please insert the coupling into the motor shaft. The insertion length must be close to the side section length of the coupling, so that the clamping end has a large enough contact surface with the shaft to ensure sufficient friction.

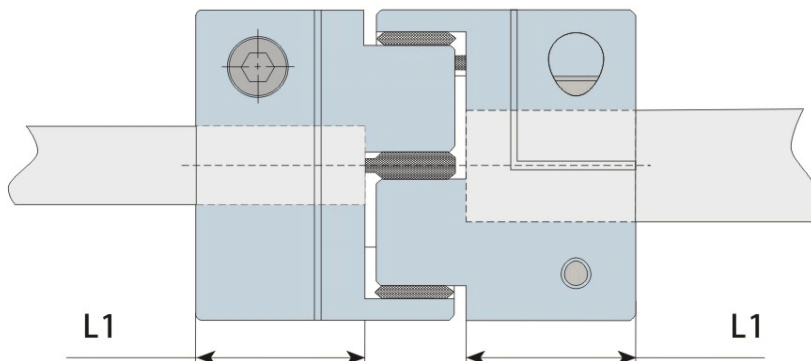

3.在夹紧螺栓处于松动状态下,请确认联轴器是否能沿轴向和旋转方向轻微移动,如果无法顺畅移动,请重新调整两轴的定心。该方法推荐用作左右同心度的简易确认方法,如果无法使用同样的确认方法,请使用其他测量方法确认安装精度。

When the clamping bolts are loose, make sure that the coupling can move slightly along the axis and rotation direction. If it can not move smoothly, please readjust the centering of the two axes. This method is recommended as a simple method to confirm the left and right concentricity. If the same method cannot be used, please use other measuring methods to confirm the installation accuracy.

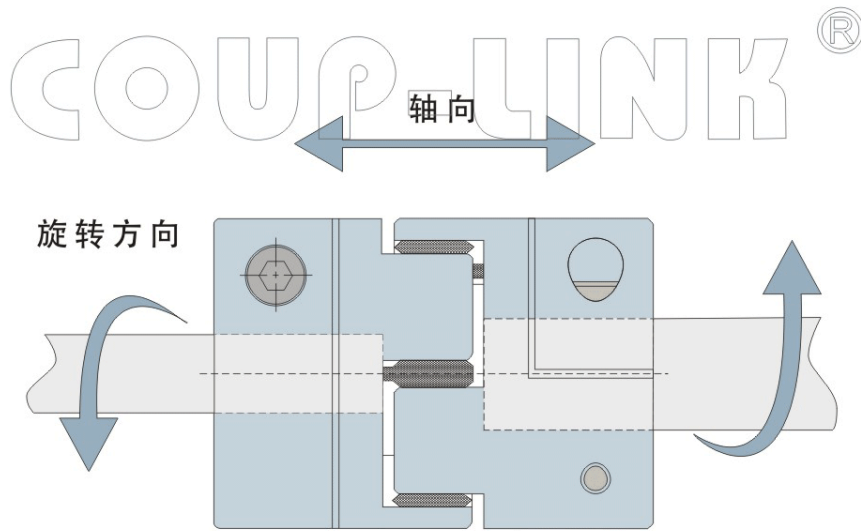

4.确认联轴器能沿轴向和旋转方向顺畅移动后,请将两根夹紧螺栓拧紧。拧紧螺栓时,请使用经过校准的扭力扳手,按参数表上所列的夹紧螺栓紧固扭矩上紧螺栓。

After confirming that the coupling can move smoothly along the axis and rotation direction, tighten the two clamping bolts. When tightening the bolt, please use the calibrated torsion plate hand to tighten the bolt according to the clamping bolt tightening torque listed in the parameter table.

5.作为夹紧螺栓的初期防松措施,建议运行一段时间后,再次使用正确紧固扭矩进行再拧紧。

As an initial anti-loosening measure of clamping bolt, it is suggested that after running for a period of time, the correct tightening torque should be used again for tightening.

弹性体性能表 Elastomer Performance Table

弹性体硬度 Elastomer Hardness	颜色 Colour	材质 Material	允许使用温度范围[持续温度] Permissible temperature range Continuous temperature(°C)	允许使用温度范围[瞬间温度] Permissible temperature range Instantaneous temperature(°C)	使用外径范围 Outer Diameter Range	典型应用 Application
90 Sh-A	黄色(Y)图	聚氨酯 (Polyurethane)	-40°C to +90°C	-50°C to +120°C	14mm-105mm	伺服电机, 步进电机, 电子测量和控制系统的传动。 Drive of servo motor, stepping motor, electronic measurement and control system
98 Sh-A	红色(R)图	聚氨酯 (Polyurethane)	-30°C to +90°C	-40°C to +120°C	14mm-135mm	伺服电机, 步进电机, 定位, 主轴, 高载荷的传动。 Servo motor, stepping motor, positioning, spindle, high load transmission
64 Sh-D	绿色(G)图	聚氨酯 (Polyurethane)	-20°C to +110°C	-30°C to +120°C	55mm-105mm	伺服电机, 步进电机, 定位, 主轴, 高载荷, 高扭转刚性的传动。 Servo motor, stepping motor, positioning, spindle, high load, high torsional rigid transmission



黄色(Y)图



红色(R)图



绿色(G)图

梅花联轴器中间弹性体尺寸 Curved Jaw Dimensions

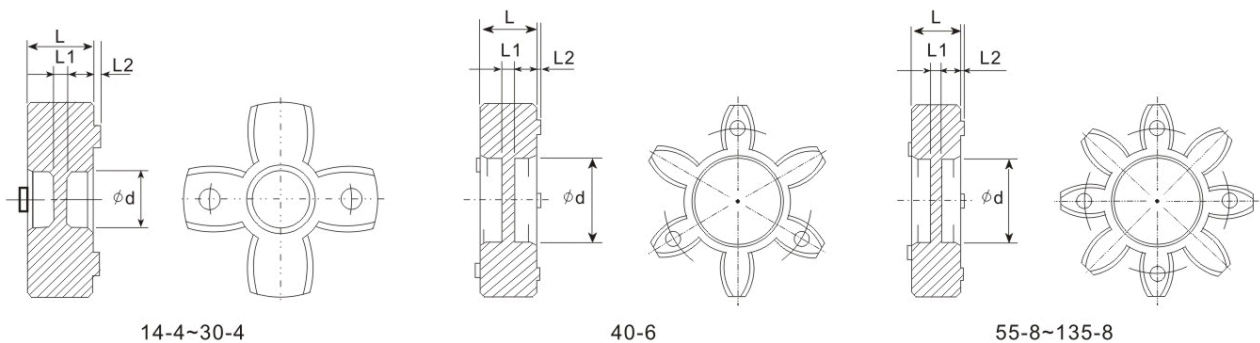

外型尺寸 Dimensions

单位 (unit): mm

弹性体型号 Model	L	L1	L2	φd
40-6	12.2	3.4	1.5	18.2
55-8	14.0	4.0	1.5	26.6
65-8	15.0	4.6	2.0	30.0
80-8	18.6	5.6	2.0	38.0
95-8	20.7	5.7	2.0	46.8
105-8	21.4	6.4	2.5	51.0

说明:

如需弹性体通孔,请定货时注明。

Note:

If elastomer through holes are required, please specify when ordering.

COUP-LINK®

LK17 系列

LK17 Series

I.定位螺丝固定型梅花联轴器
I.Setscrew Type (Curved Jaw)

特点 Features

- 中间弹性体联接
- 可吸收振动、补偿径向、角向和轴向偏差
- 抗油与电气绝缘
- 顺时针与逆时针回转特性完全相同
- 有三种不同硬度弹性体
- 定位螺丝固定



- Coupling assembled by pressing a polyurethane sleeve into hubs on both sides
- Can absorb vibration, parallel, angular misalignments and shaft end-play
- Resistance to oil and electrical insulation
- Identical clockwise and anticlockwise rotational characteristics
- Three different hardness elastic spiders are available
- Setscrew type

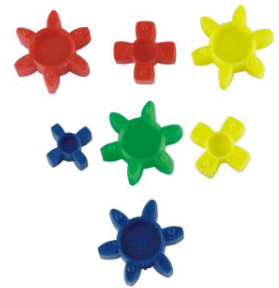

选型举例：Ordering Information

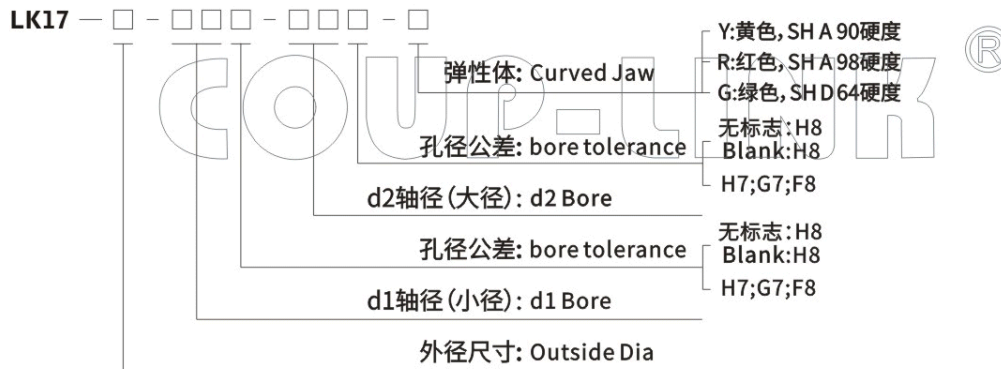

胶体选配说明:标准情况下,胶体选配为:
LK17-42~LK17-108; LK17-C56~LK17-C108: 胶体配红色。

Note: Standard:
LK17-56~LK17-108; LK17-C56~LK17-C108:Red Insert.

例：LK17-42-14-19-R

LK17: 系列号, 材料为铝合金

42: 外径尺寸: 42mm, 定位螺丝固定

14: d1孔径为: 14mm,孔公差H8

19: d2孔径为: 19mm,孔公差H8

R: 弹性体为红色,SHA 98硬度

孔径公称请按照d1(小径)-d2(大径)的顺序标示

Example: LK17-42-14-19-R

LK17: Series NO, Material: Aluminum Alloy

42: Outside Dia: 42mm, Setscrew Type

14: d1 Bore: 14mm, H8

19: d2 Bore: 19mm, H8

R: red, SHA 98

Please mark the bore diameter in the order of d1 (minor diameter) - d2 (major diameter)

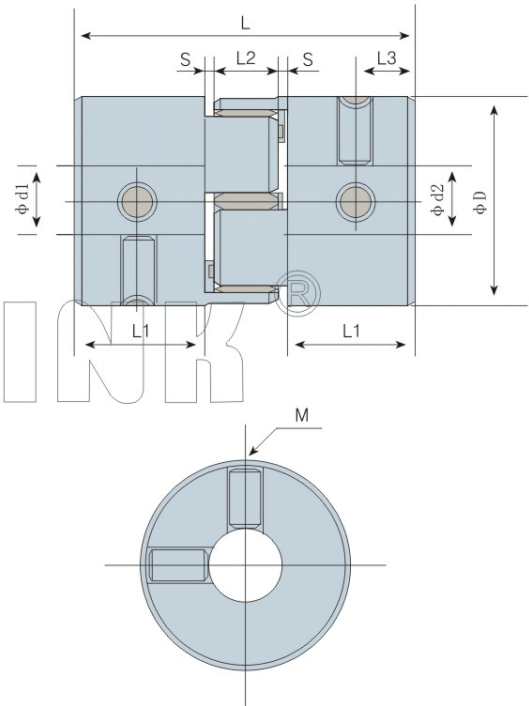

外型尺寸 Dimensions

单位 (unit): mm

型号 Model	d1 · d2		ΦD	L	L1	L2	S	L3	M	拧紧力矩 Tightening Torque (N · m)
	最小孔径 Min · Bore	最大孔径 Max · Bore								
LK17-42-□□□-□□□□-□	11	24	42	66	25.5	12	1.5	8.5	M6	6.3
LK17-56-□□□-□□□□-□	15	32	56	78	30.85	13.3	1.5	10	M6	6.3
LK17-66-□□□-□□□□-□	20	35	66	90	35.75	15.5	1.5	10.5	M8	15
LK17-82-□□□-□□□□-□	30	45	82	114	45.75	19.5	1.5	15.5	M8	15
LK17-98-□□□-□□□□-□	38	60	98	126	50.25	22.5	1.5	17	M10	29.5
LK17-108-□□□-□□□□-□	38	60	108	140	57	23	1.5	23	M10	29.5

说明:

1.对于上表以外的孔径, 如需定货, 可另行提供服务, 请向本公司洽询。

2.对方安装轴公差为h7,h8级, 如轴公差为其他公差, 请提供公差要求由厂家定做。

Note:

1. For other bore sizes which are not listed above, customized ones are available, please consult us.

2. Standard bore tolerance is for the shaft with tolerance h7 or h8, if other tolerance is required, please consult us.

标准孔径 Standard Bore Diameter

单位 (unit): mm

型号 Model	标准孔径 Standard Bore Diameter · d1·d2 (mm)																					
	11	12	14	15	16	18	19	20	22	24	25	28	30	32	35	38	40	42	45	50	55	60
LK17-42-□□□-□□□-□	•	•	•	•	•	•	•	•	•	•												
LK17-56-□□□-□□□-□				•	•	•	•	•	•	•	•	•	•	•								
LK17-66-□□□-□□□-□								•	•	•	•	•	•	•	•							
LK17-82-□□□-□□□-□													•	•	•	•	•	•	•			
LK17-98-□□□-□□□-□																•	•	•	•	•	•	•
LK17-108-□□□-□□□-□																•	•	•	•	•	•	•

技术参数 Specifications

单位 (unit): mm

型号 Model	额定扭矩 Rated Torque (N.m)	最高转速 Max. Rotational Frequency (rpm)	惯性力矩 Moment of Inertia (Kg.m ²)	静态扭矩刚性 Static Torsional Stiffness (N.m / rad)	容许径向偏差 Errors of Eccentricity (mm)	容许角向偏差 Errors of Angularity (°)	容许轴向偏差 Errors of shaft End-play (mm)	重量 N.W. (g)
LK17-42-□□□-□□□-Y	12	13000	4.4×10 ⁻⁵	570	0.1	1	+1.2 0	218
LK17-56-□□□-□□□-Y	35	10500	1.7×10 ⁻⁴	1600	0.14	1	+1.4 0	338
LK17-66-□□□-□□□-Y	95	8300	3.8×10 ⁻⁴	3000	0.15	1	+1.5 0	660
LK17-82-□□□-□□□-Y	190	7000	1.2×10 ⁻³	5300	0.17	1	+1.8 0	1139
LK17-98-□□□-□□□-Y	265	6000	2.5×10 ⁻³	6200	0.19	1	+2.0 0	1952
LK17-108-□□□-□□□-Y	310	5500	4.2×10 ⁻³	10870	0.23	1	+2.1 0	3150
LK17-42-□□□-□□□-R	21	13000	4.4×10 ⁻⁵	1200	0.06	0.9	+1.2 0	218
LK17-56-□□□-□□□-R	60	10500	1.7×10 ⁻⁴	2600	0.1	0.9	+1.4 0	338
LK17-66-□□□-□□□-R	160	8300	3.8×10 ⁻⁴	4900	0.1	0.9	+1.5 0	660
LK17-82-□□□-□□□-R	325	7000	1.2×10 ⁻³	6500	0.1	0.9	+1.8 0	1139
LK17-98-□□□-□□□-R	450	6000	2.5×10 ⁻³	8900	0.1	0.9	+2.0 0	1592
LK17-108-□□□-□□□-R	525	5500	4.2×10 ⁻³	25759	0.1	0.9	+2.1 0	3150
LK17-56-□□□-□□□-G	75	10500	1.7×10 ⁻⁴	5030	0.07	0.8	+1.4 0	338
LK17-66-□□□-□□□-G	200	8300	3.8×10 ⁻⁴	10260	0.08	0.8	+1.5 0	660
LK17-82-□□□-□□□-G	405	7000	1.2×10 ⁻³	16300	0.09	0.8	+1.8 0	1139
LK17-98-□□□-□□□-G	560	6000	2.5×10 ⁻³	26860	0.1	0.8	+2.0 0	1592
LK17-108-□□□-□□□-G	655	5500	4.2×10 ⁻³	47630	0.11	0.8	+2.1 0	3150

说明:

1. 惯性力矩和重量按最大孔径计算。
2. 最高转速未考虑动平衡。
3. 各弹性数值为20°C时数值。

Note:

1. Moment of inertia and mass figures based on the maximum shaft bores.
2. The maximum speed does not consider dynamic balance.
3. The elastic value is 20°C.

LK17 系列
LK17 Series

选项: 定位螺丝加键槽固定, 键槽尺寸
Setscrew Keyway Type

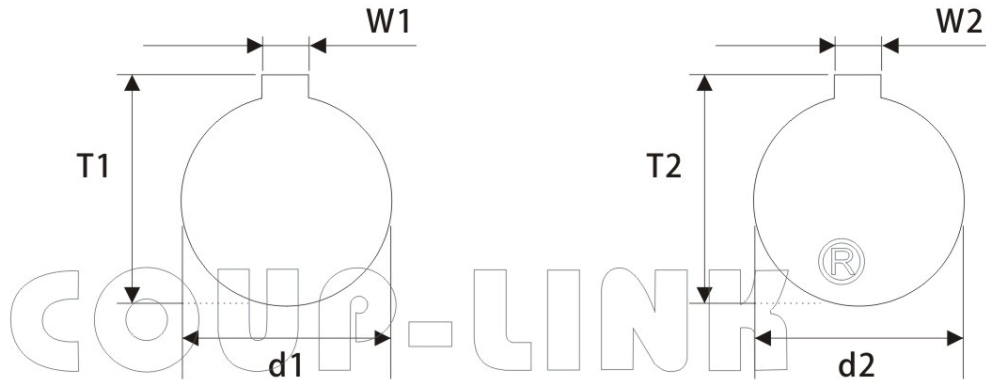

键槽标准尺寸表(国标JS9): Standard Dimension Table of Keyway(Js9) 单位 (unit):mm

孔径 φd1 φd2 Bore	键槽宽度 Keyway W1.W2 (mm)	键槽高度 Keyway T1.T2 (mm)	孔径 φd1 φd2 Bore	键槽宽度 Keyway W1.W2 (mm)	键槽高度 Keyway T1.T2 (mm)
6	2	7	32	10	35.3
8	2	9	35	10	38.3
9	3	10.4	38	10	41.3
10	3	11.4	40	12	43.3
11	4	12.8	42	12	45.3
12	4	13.8	45	14	48.8
13	5	15.3	48	14	51.8
14	5	16.3	50	14	53.8
15	5	17.3	55	16	59.3
16	5	18.3	56	16	60.3
17	5	19.3	60	18	64.4
18	6	20.8	65	18	69.4
19	6	21.8	70	20	74.9
20	6	22.8	75	20	79.9
22	6	24.8	80	22	85.4
24	8	27.3	85	22	90.4
25	8	28.3	90	25	95.4
28	8	31.3	95	25	100.4
30	8	33.3	100	28	106.4

选型举例：Ordering Information

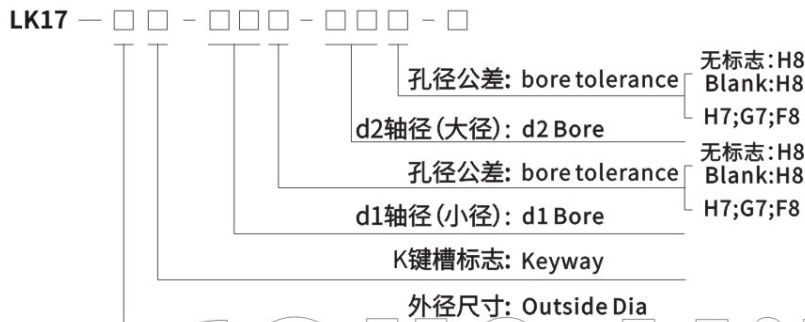

键槽说明:

两端孔都加键槽时,在联轴器外径后面加K表示,只有一端孔加键槽时,K加在要加键槽那端孔的公差后面,前面外径后不用加K,非标键槽必须提供键槽图纸

KEYWAY NOTE:

when both bores are with keyway, code "K" should be added after the outer diameter of the coupling. If only one bore is with keyway, code "K" should be added after the tolerance code of the relative bore size only (Do not add to the outer diameter). If any customized dimension required, please provide your drawings.

例:LK17-42K-14-19-R

LK17: 系列号, 材料为铝合金

- 42: 外径尺寸: 42mm, 定位螺丝固定
- 14: d1孔径为: 14mm, 孔公差H8
- 19: d2孔径为: 19mm, 孔公差H8
- K: 表示14,19两孔都加标准键槽
- R: 弹性体为红色,SHA 98硬度

Example: LK17-42K-14-19-R

LK17: Series NO, Material: Aluminum Alloy

- 42: Outside Dia: 42mm, Setscrew Type
- 14: d1 Bore: 14mm, H8
- 19: d2 Bore: 19mm, H8
- K: 14,19 bore standard keyway
- R: red, SHA 98

例:LK17-42-14K-19-R

LK17: 系列号, 材料为铝合金

- 42: 外径尺寸: 42mm, 定位螺丝固定
- 14: d1孔径为: 14mm, 孔公差H8
- 19: d2孔径为: 19mm, 孔公差H8
- K: 表示14端孔加标准键槽
- R: 弹性体为红色,SHA 98硬度

Example: LK17-42-14K-19-R

LK17: Series NO, Material: Aluminum Alloy

- 42: Outside Dia: 42mm, Setscrew Type
- 14: d1 Bore: 14mm, H8
- 19: d2 Bore: 19mm, H8
- K: 14 bore standard keyway
- R: red, SHA 98