

LK14 系列

LK14 Series

使用注意事项:

CAUTIONS:

1. 请务必遵守偏心, 偏角, 轴向的允许公差。
2. 螺栓类请务必以指定的转矩拧紧。
3. 联轴器左右内径的同轴度通过使用专用夹具实现高精度组装。万一联轴器受到强烈冲击时, 可能会无法保持组装精度而在使用中发生破损, 请在操作过程中加以留意。
4. 使用环境范围为-30°C-120°C。虽具备耐水性和耐油性, 但极度粘附的环境也会导致产品劣化, 请避免此类情况。
5. 插入安装轴前, 请勿拧紧加压螺栓。

1. Be sure to observe allowable tolerances of eccentricity, deflection and axis.
2. Bolts must be tightened with specified torque.
3. The concentricity of the left and right inner diameters of the coupling can be assembled accurately by using special fixtures. In case of strong impact on the coupling, the assembly accuracy may not be maintained and the coupling may be damaged in use, please pay attention to it during operation.
4. The use range is - 30°C - 120°C. Despite water and oil resistance, extreme adhesion can also lead to deterioration of the product, avoid this kind of situation
5. Do not tighten the pressure bolt before inserting the mounting shaft.

安装方式:

INSTALLATION:

1. 确认联轴器的压紧螺栓有无松动, 去除轴及联轴器内径面的锈迹, 灰尘及油等。特别是, 对联轴器摩擦系数有显著影响的各类润滑脂, 绝不可有粘附。

Confirm whether the compression bolt of the coupling is loose, and remove the rust, dust and oil on the shaft and the inner diameter of the coupling. In particular, all kinds of greases that have a significant impact on the friction coefficient of the coupling must not have adhesion.

2. 请将联轴器插入电动机轴和从动轴。插入时, 请勿在联轴器的弹性元件上施加过大的压缩和拉伸力, 特别是在把联轴器安装至电动机后将联轴器插入从动轴时, 可能会因错误操作而施加过大的压缩力, 请注意。

Please insert the coupling into the motor shaft and driven shaft. When inserting, do not apply too much compression and tensile force on the elastic element of the coupling, especially when inserting the coupling into the driven shaft after installing the coupling to the motor, it may exert too much compression force due to wrong operation, please note.

3. 在加压螺栓处于松动状态下, 请确认联轴器是否能沿轴向和旋转方向轻微移动, 如果无法顺畅移动, 请重新调整两轴的定心。该方法推荐用作左右同轴度的简易确认方法, 如果无法使用同样的确认方法, 请使用其他测量方法确认安装精度。

When the compression bolt is loose, please confirm whether the coupling can move slightly along the axial direction and rotation direction. If it cannot move smoothly, please readjust the centering of the two shafts. This method is recommended as a simple confirmation method of left and right concentricity. If the same confirmation method cannot be used, please use other measurement methods to confirm the installation accuracy.

4. 调整好同轴度后, 将加压螺栓按对角轻轻拧紧。

After the coaxiality is adjusted, tighten the pressure bolt slightly diagonally.

5. 确认轴向无压缩, 拉伸等作用力后, 请将加压螺栓按对角顺序拧紧。拧紧螺栓时, 请使用经过校准的扭力扳手, 并按技术参数表的拧紧扭矩拧紧。

After confirming that there is no compression, tension and other forces in the axial direction, please tighten the compression bolts in diagonal sequence. When tightening the bolt, use the calibrated torque wrench and tighten it according to the tightening torque in the technical parameter table.

LK14 系列

LK14 Series

波纹管胀套联轴器

Locking Assemblies Coupling (Bellows)

特点 Features

- 利用胀套联接的膜片型联轴器
 - 零回转间隙, 拆装方便
 - 弹性波纹管型结构补偿径向、角向和轴向偏差
 - 顺时针与逆时针回转特性完全相同
 - 波纹材料为不锈钢材料
- Using locking assemblies connect plate springs coupling
 - Zero backlash
 - Spring action bellows configuration absorbs parallel, angular misalignments and shaft end-play
 - Identical clockwise and anticlockwise rotational characteristics
 - Bellows material: Stainless steel



选型举例: Ordering Information

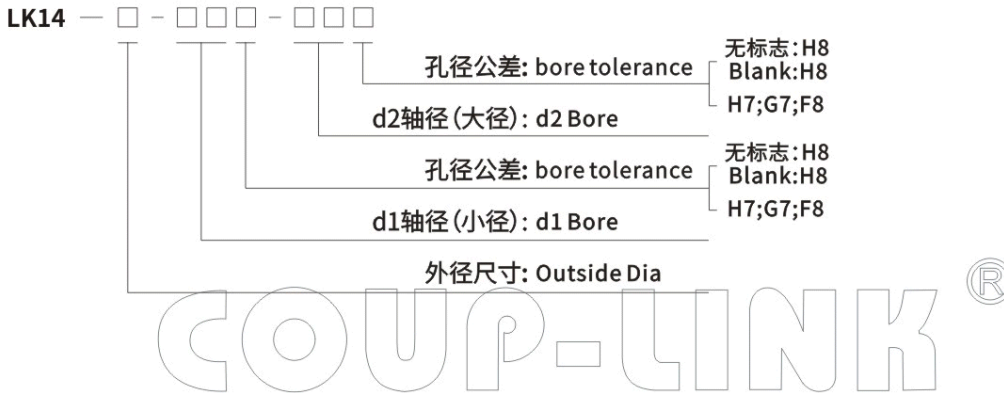

例: LK14-55-14-19

LK14: 系列号,材料为不锈钢

55: 外径尺寸:55mm

14: d1孔径为:14mm, 孔公差为H8

19: d2孔径为:19mm, 孔公差为H8

孔径公称请按照d1(小径)-d2(大径)的顺序标示

Example: LK14-55-14-19

LK14: Series NO, Material:Stainless Steel

55: Outside Dia: 55mm

14: d1 Bore: 14mm,H8

19: d2 Bore: 19mm,H8

Please mark the bore diameter in the order of d1 (minor diameter) - d2 (major diameter)

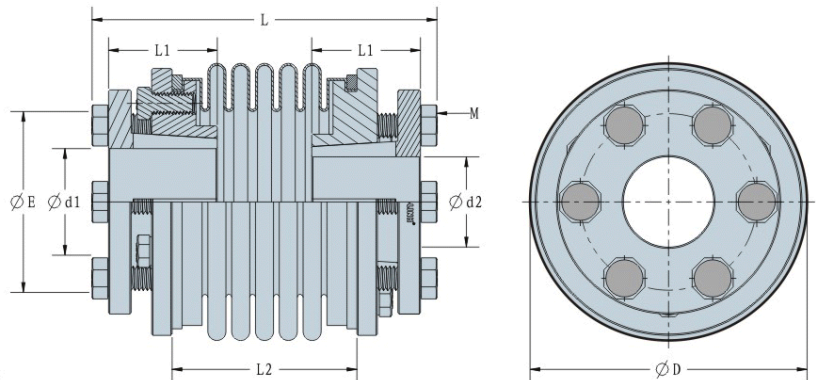

外型尺寸 Dimensions

单位 (unit): mm

型号 Model	d1 · d2		ΦD	L	L1	L2	E	M	拧紧力矩 Tightening Torque (N · m)
	最小孔径 Min · Bore	最大孔径 Max · Bore							
LK14-40-□□□-□□□	8	16	40	59	21.5	30	27	M4	3.4-4.1
LK14-55-□□□-□□□	10	20	55	68	22.5	37	37	M5	7.0-8.5
LK14-65-□□□-□□□	12	28	65	79	26.5	43	44	M6	14-15
LK14-82-□□□-□□□	14	38	82	90	32	47	55	M6	14-15

说明:

- 1.对于上表以外的孔径,如需定货,可另行提供服务,请向本公司洽询。
- 2.对方安装轴公差为h7,h8级,如轴公差为其他公差,请提供公差要求由厂家定做。

Note:

1. For other bore sizes which are not listed above, customized ones are available, please consult us.
2. Standard bore tolerance is for the shaft with tolerance h7 or h8, if other tolerance is required, please consult us.

标准孔径 Standard Bore Diameter

单位 (unit): mm

型号 Model	标准孔径 Standard Bore Diameter · d1 · d2 (mm)																				
	8	9	9.525	10	11	12	14	15	16	18	19	20	22	24	25	28	30	32	35	38	
LK14-40-□□□-□□□	•	•	•	•	•	•	•	•	•												
LK14-55-□□□-□□□				•	•	•	•	•	•	•	•	•									
LK14-65-□□□-□□□						•	•	•	•	•	•	•	•	•	•	•					
LK14-82-□□□-□□□							•	•	•	•	•	•	•	•	•	•	•	•	•	•	•

技术参数 Specifications

单位 (unit): mm

型号 Model	额定扭矩 Rated Torque (N · m)	最高转速 Max. Rotational Frequency (rpm)	转动惯量 Moment of Inertia (Kg · m ²)	静态扭矩刚性 Static Torsional Stiffness (N · m / rad)	容许径向偏差 Errors of Eccentricity (mm)	容许角向偏差 Errors of Angularity (°)	容许轴向偏差 Errors of shaft End-play (mm)	重量 N.W. (g)
LK14-40-□□□-□□□	10	8000	5.4×10^{-5}	15000	0.15	2	1	267
LK14-55-□□□-□□□	25	6000	1.8×10^{-4}	35000	0.2	2	1.5	462
LK14-65-□□□-□□□	60	5000	4.4×10^{-4}	68000	0.25	2	1.5	782
LK14-82-□□□-□□□	80	4500	1.4×10^{-3}	120000	0.28	2	1.5	1461

说明:

- 1.惯性力矩和重量按最大孔径计算。
- 2.最高转速未考虑动平衡。

Note:

- 1.Moment of inertia and weight are based on the maximum size bores
- 2.The maximum speed does not consider dynamic balance.