

LK6 系列

LK6 Series

使用注意事项:

CAUTIONS:

1. 请务必遵守偏心, 偏角, 轴向的允许公差。
2. 螺栓类请务必以指定的扭矩拧紧。
3. 插入安装轴前, 请勿拧紧夹紧螺栓或定位螺丝。

1. Be sure to observe allowable tolerances of eccentricity, deflection and axis.
2. Bolts must be tightened with specified torque.
3. Do not tighten the clamping bolt before inserting the installation shaft.

COUP-LINK®

安装方式:

INSTALLATION:

1. 确认联轴器的夹紧螺栓, 定位螺丝有无松动, 去除轴及联轴器内径面的锈迹, 灰尘及油等。特别是, 对联轴器摩擦系数有显著影响的各类润滑脂, 绝不可有粘附。

Confirm whether the clamping bolt and positioning screw of the coupling are loose, and remove the rust, dust and oil on the shaft and the inner diameter of the coupling. In particular, all kinds of greases that have a significant impact on the friction coefficient of the coupling must not have adhesion.

2. 请将联轴器插入联接轴。插入时, 请勿在联轴器上施加过大的压缩和拉伸力, 特别是在把联轴器安装至电动机后将联轴器插入从动轴时, 可能会因错误操作而施加过大的压缩力, 请注意。

Please insert the coupling into the coupling shaft. When inserting, do not apply too much compression and tensile force on the coupling, especially when inserting the coupling into the driven shaft after installing the coupling to the motor, it may exert too much compression force due to wrong operation, please note.

3. 在夹紧螺栓或定位螺丝处于松动状态下, 请确认联轴器是否能沿轴向和旋转方向轻微移动。如果无法顺畅移动, 请重新调整两轴的定心。该方法推荐用作左右同心度的简易确认方法, 如果无法使用同样的确认方法, 请使用其他测量方法确认安装精度。

When the clamping bolt or positioning screw is loose, please confirm whether the coupling can move slightly along the axial direction and rotation direction. If the movement is not smooth, please readjust the centering of the two shafts. This method is recommended as a simple confirmation method of left and right concentricity. If the same confirmation method cannot be used, please use other measurement methods to confirm the installation accuracy.

4. 安装轴原则上为圆轴, 当使用非圆轴时, 请注意下图所示的安装位置。(请注意勿使键槽, D型切槽进入灰色部份一侧), 轴安装位置不当可能会造成联轴发生破损, 轴夹持力下降。为获得令人满意的联轴器性能, 我们建议使用圆轴。

In principle, the installation shaft is a circular shaft. When using a non-circular shaft, please pay attention to the installation position shown in the figure below. (please pay attention not to make the keyway, d-groove enter the gray part of the side). Improper installation position of the shaft may cause damage to the coupling and decrease the shaft clamping force. To obtain satisfactory coupling performance, we recommend the use of round shafts.

推荐安装方式:

RECOMMENDED INSTALLATION METHOD:

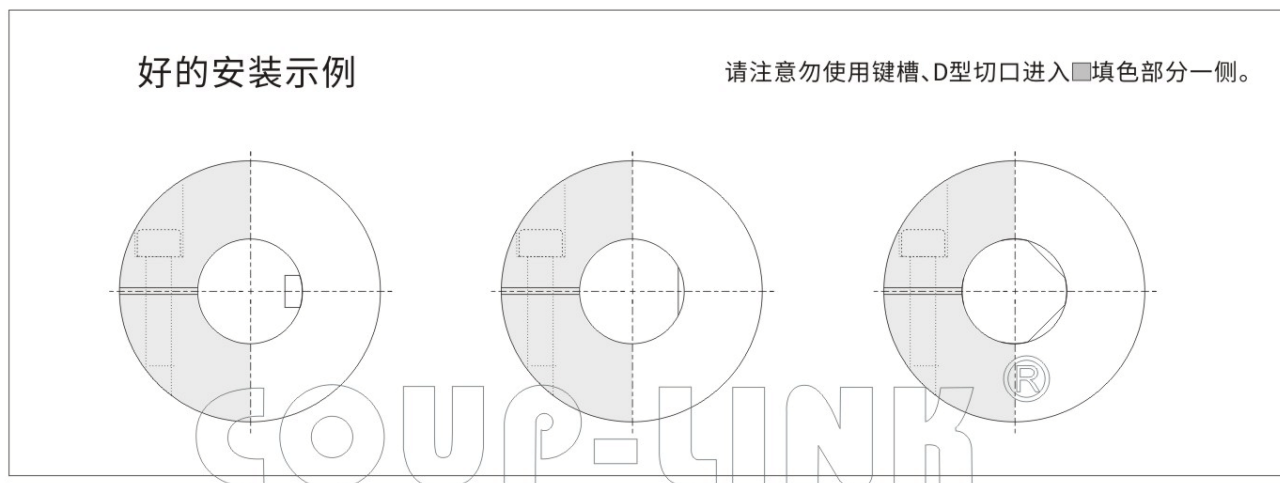

不推荐安装方式:

INSTALLATION IS NOT RECOMMENDED:

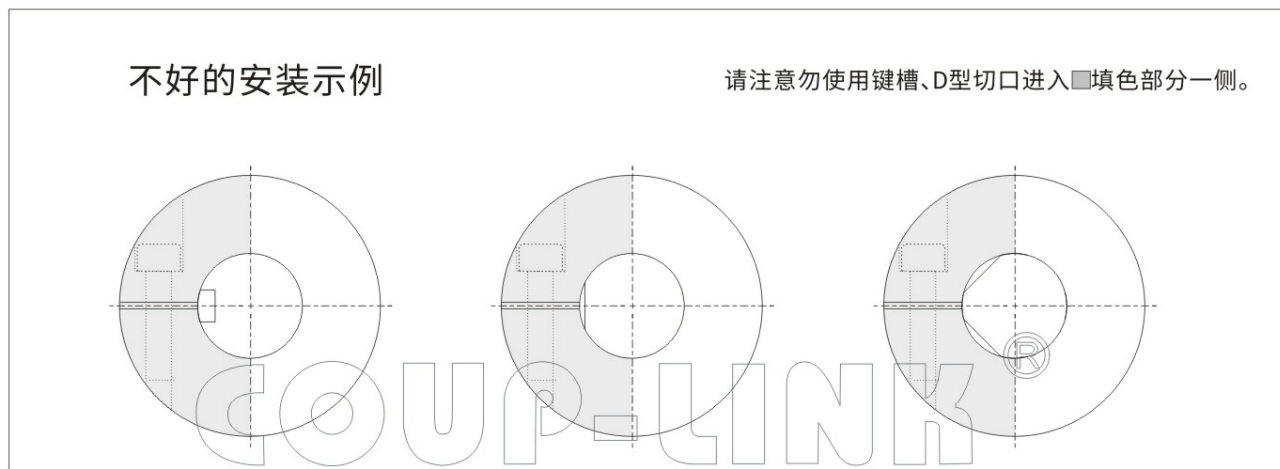

5.确认轴向无压缩,拉伸等作用力后,请将夹紧螺栓或定位螺丝拧紧。拧紧螺栓时,请使用经过校准的扭力扳手,并按参数表所列的紧固扭矩范围内进行拧紧。

After confirming that there is no compression, tension and other forces in the axial direction, please tighten the clamping bolt or positioning screw. When tightening the bolts, use a calibrated torque wrench and tighten according to the tightening torque range listed in the parameter table.

6.作为夹紧螺栓的初期防松措施,建议运行一段时间后,再次使用正确紧固扭矩进行再拧紧。

As an initial anti loose measure of clamping bolt, it is recommended to use correct tightening torque again for re tightening after a period of operation.

LK6 系列

LK6 Series

I.定位螺丝固定波纹式(波纹管联轴器)
I. Setscrew Type(Bellows)

特点 Features

- 高扭矩刚性和灵敏度
- 零回转间隙
- 波纹管结构补偿径向、角向和轴向偏差
- 顺时针与逆时针回转特性完全相同
- 定位螺丝固定
- High torque capacity and excellent response
- Zero backlash
- Spring action bellows configuration absorbs parallel, angular misalignments and shaft end-play
- Identical clockwise and anticlockwise rotational characteristics
- Setscrew type

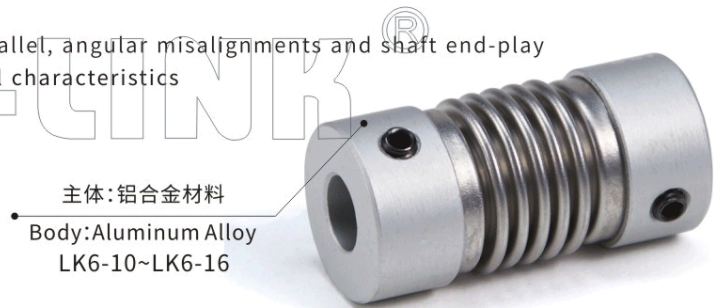

选型举例 : Ordering Information

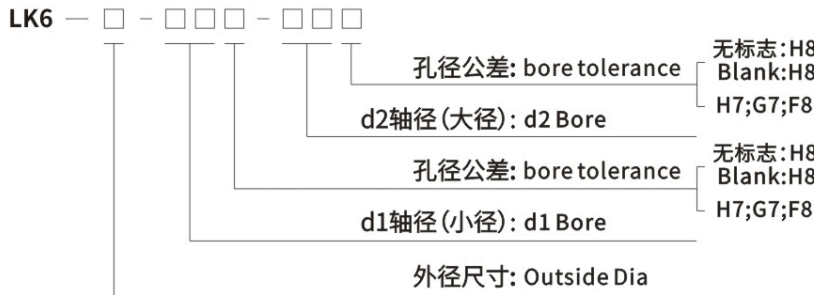

例: LK6-25-08-10

LK6: 系列号, 材料为铝合金

25: 外径尺寸: 25mm, 定位螺丝固定

08: d1孔径为: 08mm, 孔公差为H8

10: d2孔径为: 10mm, 孔公差为H8

孔径公称请按照d1(小径)-d2(大径)的顺序标示

Example: LK6-25-08-10

LK6: Series NO, Material: Aluminum Alloy

25: Outside Dia: 25mm, Setscrew Type

08: d1 Bore: 08mm, H8

10: d2 Bore: 10mm, H8

Please mark the bore diameter in the order of d1 (minor diameter) - d2 (major diameter)

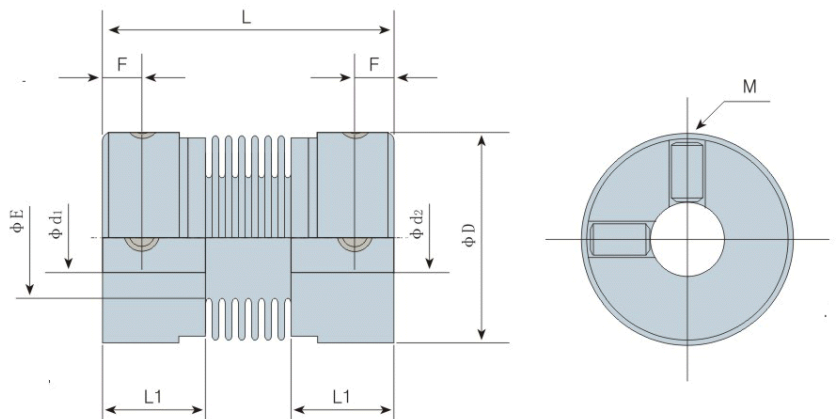

外型尺寸 Dimensions

单位 (unit): mm

型号 Model	d1 · d2		ΦD	L	L1	F	E	M	拧紧力矩 Tightening Torque (N · m)
	最小孔径 Min · Bore	最大孔径 Max · Bore							
LK6-10-□□□-□□□	2	4	10	18	4.75	2.5	6	M2	0.4
LK6-12-□□□-□□□	3	6.35	12	23.5	7.5	3.0	7	M2.5	0.5
LK6-16-□□□-□□□	3	8	16	27	9.45	3.0	9.5	M3	0.7
LK6-20-□□□-□□□	4	12	20	29	10.4	3.0	12.5	M4	1.9
LK6-25-□□□-□□□	5	12	25	34	11.4	4.0	16	M4	1.9
LK6-32-□□□-□□□	8	14	32	38	11.65	4.0	22	M4	1.9
LK6-32L-□□□-□□□	8	14	32	49	11.65	4.0	22 [®]	M4	1.9
LK6-40-□□□-□□□	10	16	40	51	15.9	4.5	27	M5	3.7
LK6-55-□□□-□□□	12	24	55	57	15	5.0	37.5	M6	6.3

说明:

1. 对于上表以外的孔径, 如需定货, 可另行提供服务, 请向本公司洽询。
2. 对方安装轴公差为h7, h8级, 如轴公差为其他公差, 请提供公差要求由厂家定做。

Note:

1. For other bore sizes which are not listed above, customized ones are available, please consult us.
2. Standard bore tolerance is for the shaft with tolerance h7 or h8, if other tolerance is required, please consult us.

标准孔径 Standard Bore Diameter

单位 (unit): mm

型号 Model	标准孔径 Standard Bore Diameter · d1 · d2 (mm)																					
	2	3	4	5	6	6.35	7	8	9	9.525	10	11	12	14	15	16	18	19	20	22	24	
LK6-10-□□□-□□□	•	•	•																			
LK6-12-□□□-□□□		•	•	•	•	•																
LK6-16-□□□-□□□		•	•	•	•	•	•	•														
LK6-20-□□□-□□□			•	•	•	•	•	•	•	•	•	•	•									
LK6-25-□□□-□□□				•	•	•	•	•	•	•	•	•	•									
LK6-32-□□□-□□□								•	•	•	•	•	•	•								
LK6-32L-□□□-□□□								•	•	•	•	•	•	•								
LK6-40-□□□-□□□											•	•	•	•	•	•						
LK6-55-□□□-□□□														•	•	•	•	•	•	•	•	•

技术参数 Specifications

单位 (unit): mm

型号 Model	额定扭矩 Rated Torque (N.m)	最高转速 Max. Rotational Frequency (rpm)	惯性力矩 Moment of Inertia (Kg.m ²)	静态扭矩刚性 Static Torsional Stiffness (N.m / rad)	容许径向偏差 Errors of Eccentricity (mm)	容许角向偏差 Errors of Angularity (°)	容许轴向偏差 Errors of shaft End-play (mm)	重量 N.W. (g)
LK6-10-□□□-□□□	0.2	28000	3.0×10^{-8}	78	0.1	1.5	+0.3 -1.0	3.4
LK6-12-□□□-□□□	0.3	25000	9.0×10^{-8}	81	0.1	1.5	+0.3 -1.0	4.5
LK6-16-□□□-□□□	0.8	20000	3.8×10^{-7}	100	0.1	1.5	+0.3 -1.0	9.7
LK6-20-□□□-□□□	1.5	15000	9.5×10^{-7}	160	0.1	1.5	+0.3 -1.0	14
LK6-25-□□□-□□□	2.0	13000	2.6×10^{-6}	220	0.15	2.0	+0.5 -1.3	28
LK6-32-□□□-□□□	2.5	10000	7.9×10^{-6}	310	0.2	2.0	+0.5 -1.3	52
LK6-32L-□□□-□□□	2.5	10000	8.9×10^{-6}	310	0.2	2.0	+0.5 -1.3	57
LK6-40-□□□-□□□	10	8000	3.2×10^{-5}	520	0.2	2.0	+0.7 -1.5	132
LK6-55-□□□-□□□	25	6000	1.1×10^{-5}	850	0.2	2.0	+0.7 -1.5	240

说明:

1. 惯性力矩和重量按最大孔径计算。
2. 扭矩刚性为元件部份的测量值。
3. 最高转速未考虑动平衡。

Note:

1. Moment of inertia and mass figures based on the maximum shaft bores.
2. Torque rigidity is the measured value of component part.
3. The maximum speed does not consider dynamic balance.

COUP-LINK®

LK6 系列

LK6 Series

选项: 定位螺丝加键槽固定, 键槽尺寸

Setscrew Keyway Type

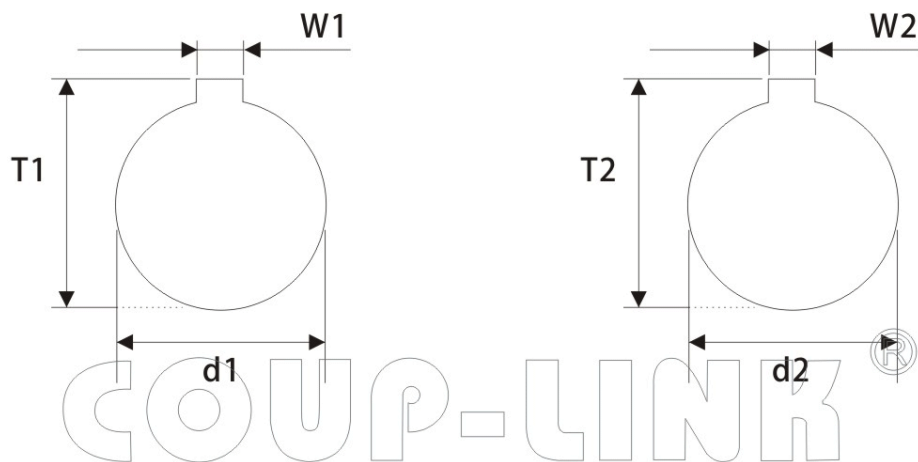

单位 (unit): mm

键槽标准尺寸表(国标JS9): Standard Dimension Table of Keyway(Js9)

孔径 φd1 φd2 Bore	键槽宽度 Keyway W1.W2 (mm)	键槽高度 Keyway T1.T2 (mm)	孔径 φd1 φd2 Bore	键槽宽度 Keyway W1.W2 (mm)	键槽高度 Keyway T1.T2 (mm)
6	2	7	32	10	35.3
8	2	9	35	10	38.3
9	3	10.4	38	10	41.3
10	3	11.4	40	12	43.3
11	4	12.8	42	12	45.3
12	4	13.8	45	14	48.8
13	5	15.3	48	14	51.8
14	5	16.3	50	14	53.8
15	5	17.3	55	16	59.3
16	5	18.3	56	16	60.3
17	5	19.3	60	18	64.4
18	6	20.8	65	18	69.4
19	6	21.8	70	20	74.9
20	6	22.8	75	20	79.9
22	6	24.8	80	22	85.4
24	8	27.3	85	22	90.4
25	8	28.3	90	25	95.4
28	8	31.3	95	25	100.4
30	8	33.3	100	28	106.4

选型举例：Ordering Information

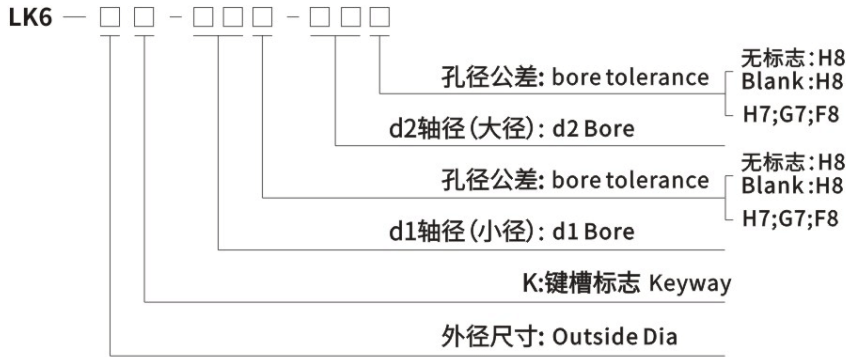

键槽说明:

两端孔都加键槽时,在联轴器外径后面加K表示,只有一端孔加键槽时,K加在要加键槽那端孔的公差后面,前面外径后不用加K,非标键槽必须提供键槽图纸

KEYWAY NOTE:

when both bores are with keyway, code "K" should be added after the outer diameter of the coupling. If only one bore is with keyway, code "K" should be added after the tolerance code of the relative bore size only (Do not add to the outer diameter). If any customized dimension required, please provide your drawings.

例:LK6-20K-08-10

LK6: 系列号, 材料为铝合金

20: 外径尺寸: 20mm定位螺丝固定

08: d1孔径为: 08mm,孔公差为H8

10: d2孔径为: 10mm,孔公差为H8

K: 表示08,10两孔都加标准键槽

孔径公称请按照d1(小径)-d2(大径)的顺序标示

Example: LK6-20K-08-10

LK6: Series NO, Material :Aluminum alloy

20:Outside Dia:20mm,Setcrew Type

08: d1 Bore: 10mm,H8

10: d2 Bore: 10mm,H8

K: 08,10 bore standard keyway

Please mark the bore diameter in the order of d1 (minor diameter) - d2 (major diameter)

例:LK6-20-08K-10

LK6: 系列号, 材料为铝合金

20: 外径尺寸: 20mm定位螺丝固定

08: d1孔径为: 08mm,孔公差为H8

10: d2孔径为: 10mm,孔公差为H8

K: 表示只有08孔加标准键槽

孔径公称请按照d1(小径)-d2(大径)的顺序标示

Example: LK6-20-08K-10

LK6: Series NO, Material : Aluminum alloy

20:Outside Dia:20mm,Setcrew Type

08: d1 Bore: 10mm,H8

10: d2 Bore: 10mm,H8

K: 08 bore standard keyway

Please mark the bore diameter in the order of d1 (minor diameter) - d2 (major diameter)