

使用注意事项:

CAUTIONS:

- 1.请务必遵守偏心, 偏角, 轴向的允许公差。
 - 2.螺栓类请务必以指定的扭矩拧紧。
 - 3.联轴器左右内径的同心病通过使用专用设备实现高精度生产。万一联轴器受到强烈冲击时,可能会无法保持高精度而在使用中发生破损,请在操作过程中加以留意。
 - 4.使用环境范围为-30°C-120°C。虽具备耐水性和耐油性,但极度粘附的环境也会导致产品劣化,请避免此类情况。
 - 5.插入安装轴前,请勿拧紧夹紧螺栓。
1. Be sure to observe allowable tolerances of eccentricity, deflection and axis.
 2. Bolts must be tightened with specified torque.
 3. The concentricity of the left and right inner diameter of the coupling is achieved by using special equipment. In case that the coupling is under strong impact, it may not be able to maintain high accuracy and be damaged in use, please pay attention to it during operation.
 4. The use range is - 30°C - 120°C. Despite water and oil resistance, extreme adhesion can also lead to deterioration of the product, avoid this kind of situation.
 5. Do not tighten the clamping bolt before inserting the installation shaft.

安装方式:

INSTALLATION:

- 1.确认联轴器上的螺栓有无松动, 去除轴及联轴器内径面的锈迹, 灰尘及油等。特别是,对联轴器摩擦系数有显著影响的各类润滑脂, 绝不可有粘附。
Confirm whether the bolts on the coupling are loose, and remove the rust, dust and oil on the shaft and the inner diameter of the coupling. In particular, all kinds of greases that have a significant impact on the friction coefficient of the coupling must not have adhesion.
- 2.请将联轴器插入电动机轴。插入时, 请勿在联轴器上施加过大的压缩和拉伸力, 特别是在把联轴器安装至电动机后将联轴器插入从动轴时, 可能会因错误操作而施加过大的压缩力, 请注意。
Please insert the coupling into the motor shaft. When inserting, do not apply excessive compression and tension force on the elastic components of the coupling, especially when inserting the coupling into the driven shaft after installing the coupling to the motor, excessive compression force may be exerted due to incorrect operation, please note.
- 3.在固定螺栓或夹紧螺栓处于松开状态下, 请确认联轴器是否能沿轴向和旋转方向轻微移动, 如果无法顺畅移动, 请重新调整两轴的定心。该方法推荐用作左右同心度的简易确认方法, 如果无法使用同样的确认方法, 请使用其他测量方法确认安装精度。
When the fixed bolt or clamping bolt is loose, please confirm whether the coupling can move slightly along the axial direction and rotation direction. If it cannot move smoothly, please readjust the centering of the two shafts. This method is recommended as a simple confirmation method of left and right concentricity. If the same confirmation method cannot be used, please use other measurement methods to confirm the installation accuracy.

LK2 系列

LK2 Series

II.定位螺丝固定螺纹式

II.Setscrew Type(Spiral)

特点 Features

- 一体成型的金属弹性联轴器
- 零回转间隙
- 弹性作用补偿径向、角向、轴向偏差
- 高弹性角向误差补偿大
- 定位螺丝固定
- 铝合金及不锈钢材料
- One-piece metallic spring coupling
- Zero backlash
- Absorption of parallel, angular misalignments and shaft end-play By spring action
- Absorption of large angular misalignments by spring action
- Setscrew type
- Material Aluminum alloy and stainless steel



主体: 铝合金材料
Body: Aluminum Alloy

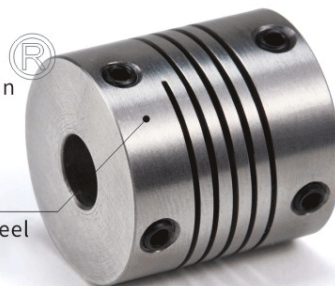

主体: 不锈钢材料
Body: Stainless Steel

选型举例: Ordering Information

□ LK2 — □ - □□□ - □□□□ M

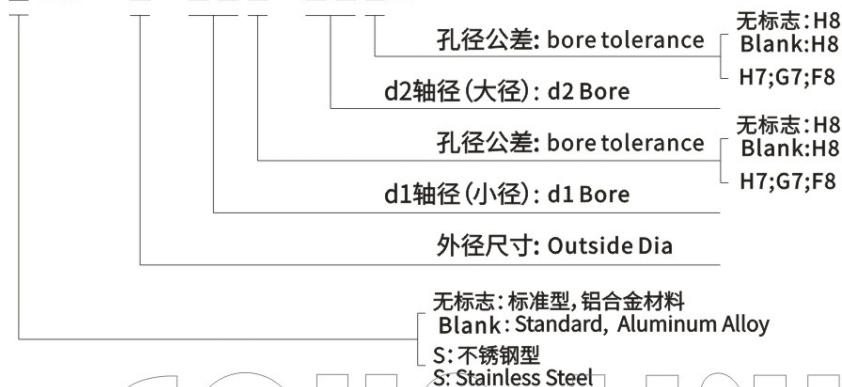

例: LK2-100-08-10M

- LK2: 系列号, 材料为铝合金
 - 100: 外径尺寸: 25.4mm, 定位螺丝固定
 - 08: d1轴径为: 08mm, 孔公差为H8
 - 10: d2轴径为: 10mm, 孔公差为H8
 - M: 螺纹式
- 孔径公称请按照d1(小径)-d2(大径)的顺序标示

Example: LK2-100-08-10M

- LK2: Series NO, Material: Aluminum Alloy
- 100: Outside Dia: 25.4mm, Setscrew Type
- 08: d1 Bore: 08mm, H8
- 10: d2 Bore: 10mm, H8
- M: Spiral

Please mark the bore diameter in the order of d1 (minor diameter) - d2 (major diameter)

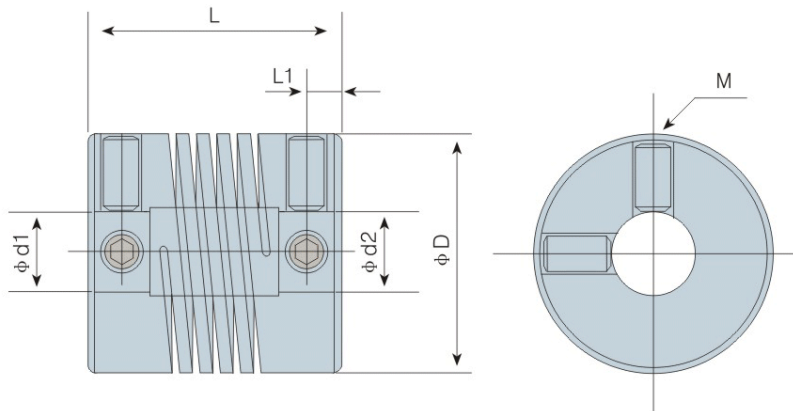

外型尺寸 Dimensions

单位 (unit): mm

型号 Model	d1 · d2		ΦD	L	L1	M	拧紧力矩 Tightening Torque (N · m)
	最小孔径 Min · Bore	最大孔径 Max · Bore					
LK2-075-□□□-□□□M	4	6.35	19.1	19.1	2.55	M3	0.7
SLK2-075-□□□-□□□M	4	6.35	19.1	19.1	2.55	M3	0.7
LK2-100-□□□-□□□M	5	10	25.4	25.4	3.55	M4	1.9
SLK2-100-□□□-□□□M	5	10	25.4	25.4	3.55	M4	1.9
LK2-112-□□□-□□□M	6	12.7	28.6	28.6	3.60	M5	3.7
SLK2-112-□□□-□□□M	6	12.7	28.6	28.6	3.60	M5	3.7
LK2-150-□□□-□□□M	8	15	38.1	38.1	4.15	M5	3.7
SLK2-150-□□□-□□□M	8	15	38.1	38.1	4.15	M5	3.7
LK2-200-□□□-□□□M	12	19	50.8	50.8	5.25	M6	6.3
SLK2-200-□□□-□□□M	12	19	50.8	50.8	5.25	M6	6.3

说明:

1. 对于上表以外的孔径, 如需定货, 可另行提供服务, 请向本公司洽询。
2. 对方安装轴公差为h7, h8级, 如轴公差为其他公差, 请提供公差要求由厂家定做。

Note:

1. For other bore sizes which are not listed above, customized ones are available, please consult us.
2. Standard bore tolerance is for the shaft with tolerance h7 or h8, if other tolerance is required, please consult us.

标准孔径 Standard Bore Diameter

单位 (unit): mm

型号 Model	标准孔径 Standard Bore Diameter · d1 · d2 (mm)															
	4	5	6	6.35	8	9	9.525	10	11	12	12.7	14	15	16	18	19
LK2-075-□□□-□□□M	●	●	●	●												
SLK2-075-□□□-□□□M	●	●	●	●												
LK2-100-□□□-□□□M		●	●	●	●	●	●	●								
SLK2-100-□□□-□□□M		●	●	●	●	●	●	●								
LK2-112-□□□-□□□M			●	●	●	●	●	●	●	●	●					
SLK2-112-□□□-□□□M			●	●	●	●	●	●	●	●	●					
LK2-150-□□□-□□□M					●	●	●	●	●	●	●	●	●			
SLK2-150-□□□-□□□M					●	●	●	●	●	●	●	●	●			
LK2-200-□□□-□□□M										●	●	●	●	●	●	●
SLK2-200-□□□-□□□M										●	●	●	●	●	●	●

技术参数 Specifications

单位 (unit): mm

型号 Model	额定扭矩 Rated Torque (N.m)	最高转速 Max. Rotational Frequency (rpm)	惯性力矩 Moment of Inertia (Kg.m ²)	静态扭矩刚性 Static Torsional Stiffness (N.m/rad)	容许径向偏差 Errors of Eccentricity (mm)	容许角向偏差 Errors of Angularity (°)	容许轴向偏差 Errors of shaft End-play (mm)	重量 N.W. (g)
LK2-075-□□□-□□□M	0.5	10000	6.3×10^{-7}	110	0.1	2.0	±0.15	12
LK2-100-□□□-□□□M	1.4	10000	2.54×10^{-6}	170	0.1	2.0	±0.15	27
LK2-112-□□□-□□□M	1.6	8000	4.56×10^{-6}	260	0.1	2.0	±0.15	38
LK2-150-□□□-□□□M	4.2	8000	1.92×10^{-5}	330	0.1	2.0	±0.15	90
LK2-200-□□□-□□□M	9.0	6000	8.16×10^{-5}	560	0.1	2.0	±0.15	220
SLK2-075-□□□-□□□M	1.0	10000	1.78×10^{-6}	230	0.1	2.0	±0.15	35
SLK2-100-□□□-□□□M	2.2	10000	7.26×10^{-6}	320	0.1	2.0	±0.15	77
SLK2-112-□□□-□□□M	3.1	8000	1.29×10^{-5}	790	0.1	2.0	±0.15	106
SLK2-150-□□□-□□□M	7.5	8000	5.56×10^{-5}	980	0.1	2.0	±0.15	260
SLK2-200-□□□-□□□M	14.0	6000	2.37×10^{-4}	1450	0.1	2.0	±0.15	640

说明:

1. 惯性力矩和重量按最大孔径计算。
2. 最高转速未考虑动平衡。

Note:

1. Moment of inertia and weight are based on the maximum size bores
2. The maximum speed does not consider dynamic balance.

COUP-LINK®

LK2 系列

LK2 Series

选项: 定位螺丝加键槽固定, 键槽尺寸

Setscrew Keyway Type

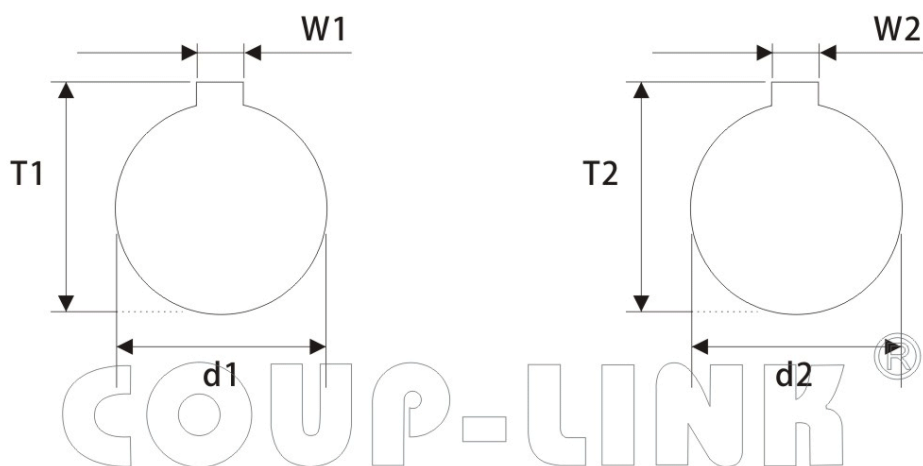

单位 (unit): mm

键槽标准尺寸表(国标JS9): Standard Dimension Table of Keyway(Js9)

孔径 φd1 φd2 Bore	键槽宽度 Keyway W1.W2 (mm)	键槽高度 Keyway T1.T2 (mm)	孔径 φd1 φd2 Bore	键槽宽度 Keyway W1.W2 (mm)	键槽高度 Keyway T1.T2 (mm)
6	2	7	32	10	35.3
8	2	9	35	10	38.3
9	3	10.4	38	10	41.3
10	3	11.4	40	12	43.3
11	4	12.8	42	12	45.3
12	4	13.8	45	14	48.8
13	5	15.3	48	14	51.8
14	5	16.3	50	14	53.8
15	5	17.3	55	16	59.3
16	5	18.3	56	16	60.3
17	5	19.3	60	18	64.4
18	6	20.8	65	18	69.4
19	6	21.8	70	20	74.9
20	6	22.8	75	20	79.9
22	6	24.8	80	22	85.4
24	8	27.3	85	22	90.4
25	8	28.3	90	25	95.4
28	8	31.3	95	25	100.4
30	8	33.3	100	28	106.4

选型举例：Ordering Information

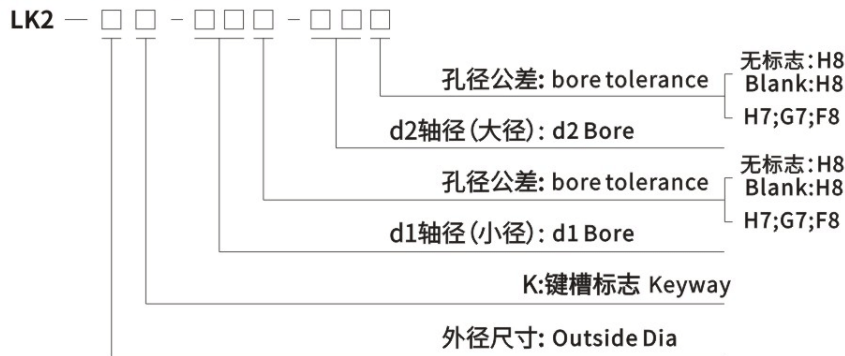

键槽说明:

两端孔都加键槽时,在联轴器外径后面加K表示,只有一端孔加键槽时,K加在要加键槽那端孔的公差后面,前面外径后不用加K,非标键槽必须提供键槽图纸

KEYWAY NOTE:

when both bores are with keyway, code "K" should be added after the outer diameter of the coupling. If only one bore is with keyway, code "K" should be added after the tolerance code of the relative bore size only (Do not add to the outer diameter). If any customized dimension required, please provide your drawings.

例:LK2-100K-08-10

LK2: 系列号, 材料为铝合金
 100: 外径尺寸: 25.4mm定位螺丝固定
 08: d1孔径为: 08mm,孔公差为H8
 10: d2孔径为: 10mm,孔公差为H8
 K: 表示08,10两孔都加标准键槽
 孔径公称请按照d1(小径)-d2(大径)的顺序标示

Example: LK2-100K-08-10

LK2: Series NO, Material :Aluminum alloy
 100:Outside Dia:25.4mm,Setcrew Type
 08: d1 Bore: 10mm,H8
 10: d2 Bore: 10mm,H8
 K: 08,10 bore standard keyway
 Please mark the bore diameter in the order of d1 (minor diameter) - d2 (major diameter)

例:LK2-100-08K-10

LK2: 系列号, 材料为铝合金
 100: 外径尺寸: 25.4mm定位螺丝固定
 08: d1孔径为: 08mm,孔公差为H8
 10: d2孔径为: 10mm,孔公差为H8
 K: 表示只有08孔加标准键槽
 孔径公称请按照d1(小径)-d2(大径)的顺序标示

Example: LK2-100-08K-10

LK2: Series NO, Material : Aluminum alloy
 100:Outside Dia:25.4mm,Setcrew Type
 08: d1 Bore: 10mm,H8
 10: d2 Bore: 10mm,H8
 K: 08 bore standard keyway
 Please mark the bore diameter in the order of d1 (minor diameter) - d2 (major diameter)