

LK27 系列

LK27 Series

使用注意事项:

CAUTIONS:

1. 请务必遵守偏心, 偏角, 轴向的允许公差。
Be sure to observe allowable tolerances of eccentricity, deflection and axis.
2. 螺栓类请务必以指定的扭矩拧紧。
Bolts must be tightened with specified torque.
3. 使用环境范围为-30°C~120°C。联轴器不具备耐水性和耐油性, 请勿在室外使用。
Couplings are designed for use within an operating temperature range of -30°C~120°C. This coupling is not waterproof and oil resistance. Do not use it outdoors.
4. 插入安装轴前, 请勿拧紧夹紧螺栓或定位螺丝。
Do not tighten the clamping bolt before inserting the installation shaft.
5. 各组件通过轴承连接, 因此产品可自由转动, 搬运时、安装时, 请注意以免受伤, 并注意不要在产品上施加过大的力。
The discs are all connected by bearings and can move freely, so be alert to injury during transport and handle so that undue force is not applied to the product.
6. 使用中请确保两轴的偏心量在 $S \times 0.25$ (最小偏心量) 至 $S \times 0.95$ (最大偏心量) 的范围内安装使用。
Use in a manner that results in the parallel misalignment of both shafts being in the range $S \times 0.25$ to $S \times 0.95$.

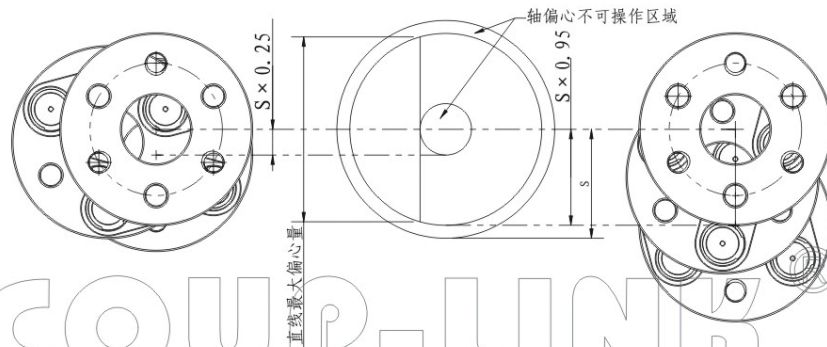

直线最大偏心量: Max.linear parallel misalignment
 轴偏心不可操作区域: Non-operable region of area exhibiting axial eccentricity
 轴偏心可操作区域: Operable region of area exhibiting axial eccentricity

型号 Model	偏心量Parallel misalignment (mm)		
	$S \times 0.25$ (Min.)	$S \times 0.95$ (Max.)	直线最大间隙Max.linear
LK27-70	9	34	65
LK27-92	18	66	128
LK27-120	23	85	165
LK27-148	23	85	165

7. 请使驱动轴 (电机轴) 与从动轴保持平行。调节联轴器两轴的安装角度误差, 使安装后及运转过程中联轴器的端面跳动低于各参数允许范围内, 以使联轴器正常运转。如端面跳动超过允许值, 联轴器会在极短的时间内发生破损。
Make the driving shaft and driven shaft parallel. Adjust the mounting angle misalignment of the two coupling shafts so that the coupling surface deflection is at or below the values of the table below after mounting and during operation. If surface deflection exceeds the allowable value, the product will break down in a very short period of time.

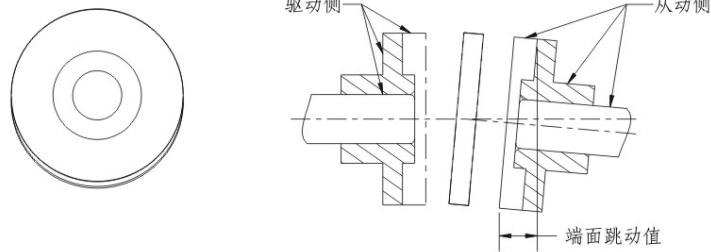

驱动侧: End disc on the driving side
 从动侧: End disc on the driven side
 端面跳动: Surface deflection
 端面跳动允许值: Allowable surface deflection



型号 Model	端面跳动允许值间隙Allowable surface deflection (mm)
LK27-70	0.15
LK27-92	0.15
LK27-120	0.20
LK27-148	0.20

8. 在设计和安装中, 请确保联轴器安装时和使用的轴向长度在相对于标准尺寸B的±1mm以内。
 When mounting a coupling, design and mount it so that the axial length during use is standard dimension $B \pm 1\text{mm}$.

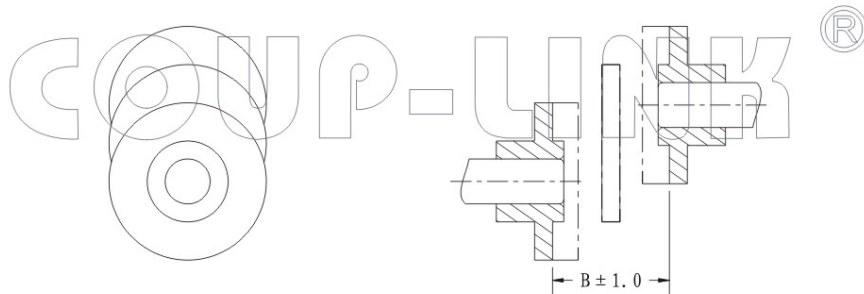

9. 请设计成联轴器上不施加弯曲负载和推力负载, 此外, 请避免在垂直或斜向安装方式下使用联轴器。
 De sign the device so that no bending or thrust loads act on the coupling. Avoid using these couplings in applications that install them vertically or obliquely.
10. 请正确选用轴承润滑油脂、加润滑油脂量和加润滑油脂周期。
 Pl ease correctly select the bearing lubricating grease, the amount of lubricating grease and the period of lubricating grease.
11. 联轴器旋转组件请安装保护罩, 安装时请注意不要使手、头发夹入盘与链杆之间。
 Mount a protective cover on the rotating part. Be careful not to pinch your hand between the discs and links when mounting.

LK27 系列

LK27 Series

I. 链杆式法兰联轴器

I. Flange Connection Coupling

特点 Features

- 链杆式联轴器是一种利用链杆曲柄运动的不同轴心联接的联轴器
- 驱动侧的能量、转速、转矩均准确传递至从动侧
- 实现了旋转时大范围的轴平行移动
- 法兰联接
- Chain couplings use different shaft centers and the crank motion of a link.
- Reliably transmits the drive-side energy to the driven side together with rotation speed and torque.
- Can translate shafts over a wide range while rotating.
- Flange connection

主体:铁合金材料

Body:Steel



选型举例 : Ordering Information

LK27 - □ F - □ □ - □ □ □

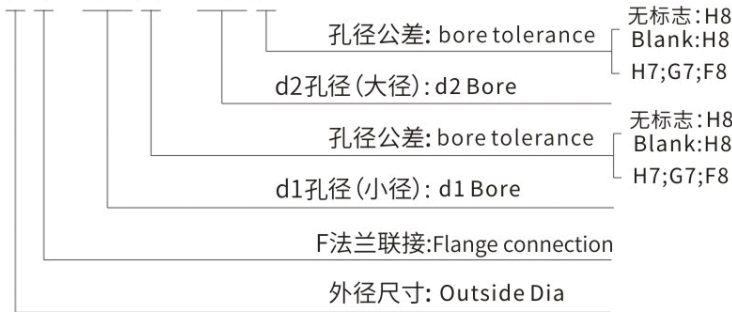

例:LK27-70F-20-24

LK27: 系列号, 材料为45#钢

70F: 外径尺寸:70mm,法兰联接

20: d1孔径为:20mm,孔公差H8

24: d2孔径为:24mm,孔公差H8

孔径公称请按照d1(小径)-d2(大径)的顺序标示

Example: LK27-70F-20-24

LK:27: Series No, Material: C45 Steel

70F: Outside Diam: 70mm, Flange Type

20: d1 Bore: 20mm, H8

24: d2 Bore: 24mm, H8

Please mark the bore diameter in the order of d1 (minor diameter) - d2 (major diameter)

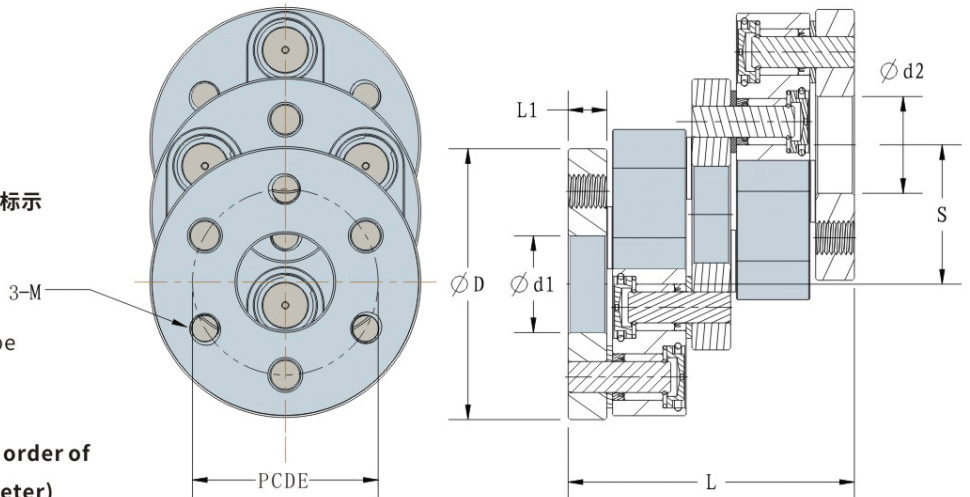

外型尺寸 Dimensions

单位 (unit): mm

型号 Model	d1 · d2		ΦD	L	L1	S	PCDE	M
	最小孔径 Min·Bore	最大孔径 Max·Bore						
LK27-70F-□□□-□□□	14	25	70	74	10	36	48	3—M8
LK27-92F-□□□-□□□	20	45	92	74	10	70	70	3—M10
LK27-120F-□□□-□□□	35	50	120	101	15	90	90	3—M12
LK27-148F-□□□-□□□	35	55	148	128	20	100	110	3—M16

说明:

- 1.对于上表以外的孔径, 如需定货, 可另行提供服务, 请向本公司洽询。
- 2.对方安装轴公差为h7,h8级, 如轴公差为其他公差, 给公差要求厂家定做。

Note:

1. For other bores not listed above, if you need to order, you can provide additional services. please contact our company.
2. The tolerance of installation axle is h7 and h8. If the axle tolerance is other tolerance, it should be customized to the manufacturer.

标准孔径 Standard Bore Diameter

单位 (unit): mm

型号 Model	标准孔径 Standard Bore Diameter · d1·d2 (mm)																			
	14	15	16	18	19	20	22	24	25	28	30	32	35	38	40	42	45	48	50	55
LK27-70F-□□□-□□□	•	•	•	•	•	•	•	•	•											
LK27-92F-□□□-□□□						•	•	•	•	•	•	•	•	•	•	•	•			
LK27-120F-□□□-□□□													•	•	•	•	•	•	•	
LK27-148F-□□□-□□□													•	•	•	•	•	•	•	•

技术参数 Specifications

单位 (unit): mm

型号 Model	链杆数量 (个数×组)	额定扭矩 Rated Torque (N.m)	最高转速 Max.Rotational Frequency (rpm)	惯性力矩 Moment of Inertia (Kg.m ²)	偏心量最小 (mm) S×0.25	偏心量最大 (mm) S×0.95	轴承基本负载 (N)	重量 N.W. (g)
LK27-70F-□□□-□□□	3×2	49	3000	7.61×10 ⁻⁴	9	34	3870	1340
LK27-92F-□□□-□□□	3×2	68	2500	1.84×10 ⁻³	18	66	3870	2070
LK27-120F-□□□-□□□	3×2	196	2500	1.16×10 ⁻²	23	85	8920	5050
LK27-148F-□□□-□□□	3×2	350	1800	2.51×10 ⁻²	25	95	14120	10900

说明:

- 1.惯性力矩和重量按最大孔径计算。
- 2.选择链杆联轴器时, 务必考虑轴承寿命时间
- 3.最高转速未考虑动平衡。

Note:

- 1.Moment of inertia and mass figures based on the maximum shaft bores
2. Torque rigidity is the measured value of component part
3. The maximum speed does not consider dynamic balance.