

## 使用注意事项:

### CAUTIONS:

1. 请务必遵守偏心, 偏角, 轴向的允许公差。
  2. 螺栓类请务必以指定的扭矩拧紧。
  3. 联轴器左右内径的同心病度通过使用专用夹具实现高精度组装。万一联轴器受到强烈冲击时, 可能会无法保持组装精度而在使用中发生破损, 请在操作过程中加以留意。
  4. 使用环境范围为-30°C-120°C。虽具备耐水性和耐油性, 但极度粘附的环境也会导致产品劣化, 请避免此类情况。
  5. 弹性元件由薄薄的不锈钢膜片组成, 使用时注意避免划伤。
  6. 插入安装轴前, 请勿拧紧夹紧螺栓。
1. Be sure to observe allowable tolerances of eccentricity, deflection and axis.
2. Bolts must be tightened with specified torque.
3. The concentricity of the left and right inner diameters of the coupling can be assembled accurately by using special fixtures. In case of strong impact on the coupling, the assembly accuracy may not be maintained and the coupling may be damaged in use, please pay attention to it during operation.
4. The use range is - 30 C - 120 C. Despite water and oil resistance, extreme adhesion can also lead to deterioration of the product, avoid this kind of situation.
5. Plate springs consist of thin stainless steel diaphragms, when using, care should be taken to avoid scratches.
6. Do not tighten the clamping bolt before inserting the installation shaft.

## 安装方式:

### INSTALLATION:

1. 确认联轴器的夹紧螺栓有无松动, 去除轴及联轴器内径面的锈迹, 灰尘及油等。特别是, 对联轴器摩擦系数有显著影响的各类润滑脂, 绝不可有粘附。  
Confirm whether the clamping bolt of the coupling is loose or not, remove rust, dust and oil on the inner diameter surface of the shaft and coupling. In particular, all kinds of greases which have a significant impact on the friction coefficient of the coupling must not have adhesion.
2. 请将联轴器插入电动机轴。插入时, 请勿在联轴器的弹性元件上施加过大的压缩和拉伸力, 特别是在把联轴器安装至电动机后将联轴器插入从动轴时, 可能会因错误操作而施加过大的压缩力, 请注意。  
Please insert the coupling into the motor shaft. When inserting, do not apply excessive compression and tension force on the elastic components of the coupling, especially when inserting the coupling into the driven shaft after installing the coupling to the motor, excessive compression force may be exerted due to incorrect operation, please note.
3. 联轴器插入电动机轴的长度如下图所示, 贯穿边节法兰全长(L1尺寸)并与轴联接, 且不得与弹性元件及另一边的轴干涉, 并保持在该位置。  
The length of the coupling inserted into the motor shaft is shown in the figure below. The full length of the flange running through the side section (L1 size) is connected with the shaft, and it is not allowed to interfere with the elastic element and the axis on the other side, and is kept in this position.

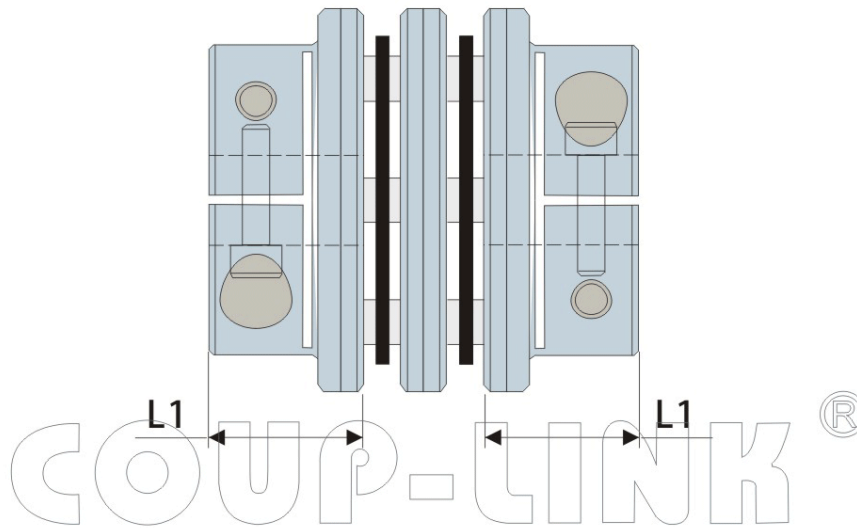

4.使千分表与电动机轴侧的夹紧发兰外径(内径同时加工面)接触,在用手旋转电动机轴侧的同时,调整并拧紧2根夹紧螺栓,使下图A,B的跳动值的差在0.02mm以下(尽可能接近零)。

Contact the micrometer with the clamping hairpin outer diameter (inner diameter processing surface) of the motor shaft side, adjust and tighten two clamping bolts while rotating the motor shaft side by hand, so that the difference between the jump values of figure A and B below 0.02 mm (as close as possible to zero).

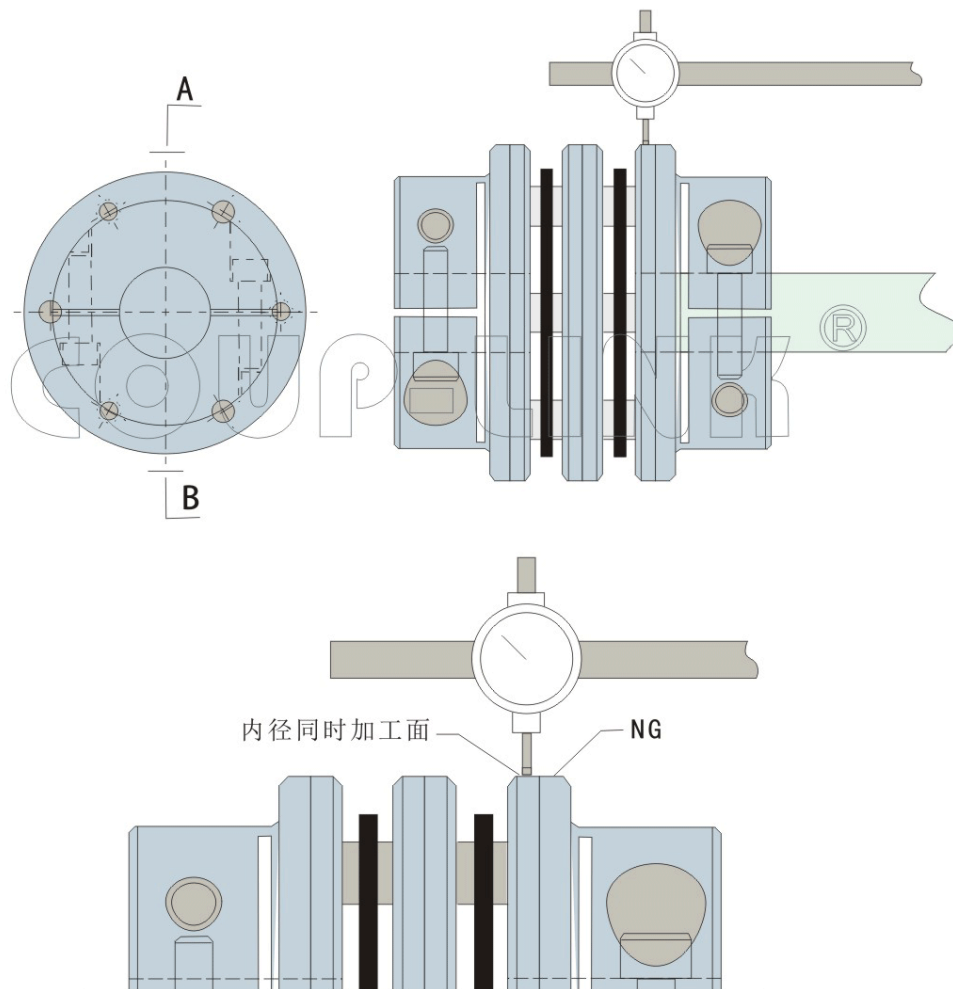

5. 在调整的同时交替拧紧2根夹紧螺栓, 最后使用经过校准的扭矩扳手将2根螺栓均以参数表上的正确紧固扭矩拧紧。

At the same time, two clamping bolts are tightened alternately. Finally, the two bolts are tightened with the correct tightening torque on the parameter table by using the calibrated torque plate hand.

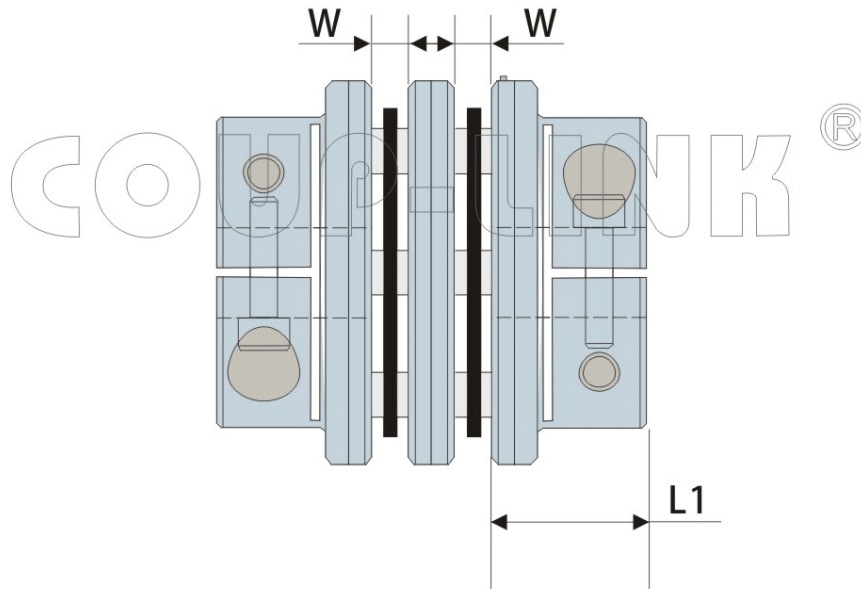

6. 请将安装了联轴器的电动机安装至机身。安装时, 将联轴器插入从动轴(滚珠丝杆等)的同时调整电动机的安装位置(定心接口), 并注意不要在弹性元件施加过大压缩, 拉伸力。

Please install the motor with coupling to the fuselage. When installing, insert the coupling into the driven shaft (ball screw, etc.) while adjusting the installation position of the motor (centring interface), and pay attention not to exert excessive compression and tension on the elastic elements.

7. 联轴器插入从动轴的长度也需达到上述L1尺寸并与轴接触, 交替拧紧2根夹紧螺栓进行预拧紧, 直至无法用手转动联轴器。

The length of the coupling inserted into the driven shaft should also reach the above L1 size and contact with the shaft, alternately tightening two clamping bolts for pre-tightening, until the coupling can not be rotated by hand.

8. 请将夹紧发兰面到面尺寸(W尺寸)控制在标准值的轴向位移允许误差的范围内。该值为假设偏心, 偏角为零时的允许值, 请尽量调小。

Please control the dimension of clamping hairdressing face to face (W dimension) within the allowable error range of the standard value of the axial displacement. This value is the allowable value when the eccentricity is assumed and the deflection angle is zero. Please adjust it as small as possible.

# LK24 系列

LK24 Series

II.多节夹紧螺丝固定式(膜片联轴器)  
II .Clamp Type (Double Spring Plates)

## 特点 Features

- 利用双夹紧联接的膜片型联轴器
- 刚性强, 传递扭矩大
- Diaphragm type coupling with double clamping connection
- High rigidity, large transmission torque.



主体:45#钢  
Body: C45 steel



## 选型举例 : Ordering Information

LK24 — C C □ — □ □ □ — □ □ □ WP



## 例: LK24-CC60-20-24WP

LK24: 系列号, 材料为45#钢

CC60: 外径尺寸: 60mm,双夹紧螺丝固定

20: d1孔径为: 20mm,孔公差为H8

24: d2孔径为: 24mm,孔公差为H8

WP: 双膜片

孔径公称请按照d1(小径)-d2(大径)的顺序标示

### Example: LK24-CC60-20-24WP

LK24: Series NO, material: C45 steel

CC60:Outside Dia:60mm, double clamp type

20: d1 bore: 10mm,H8

24: d2 bore: 14mm,H8

WP: Double spring plates

Please mark the bore diameter in the order of d1 (minor diameter) - d2 (major diameter)

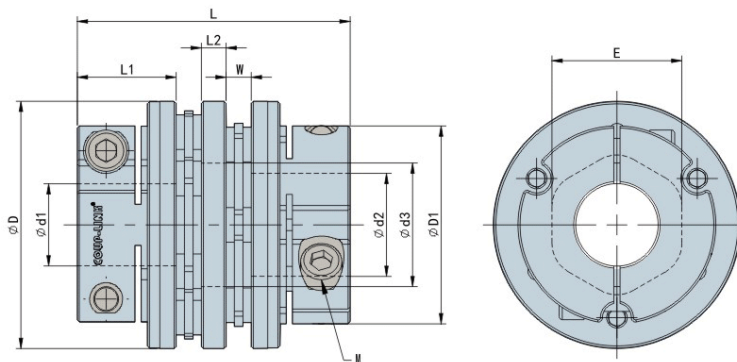

## 外型尺寸 Dimensions

单位 (unit):mm

型号 Model	φd1·φd2 孔径范围 Bore rang	ΦD	ΦD1	L	W	L1	L2	d3	E	M	拧紧力矩 Tightening Torque (N·m)
LK24-CC60-□□□-□□□WP	12≤d1.d2≤22	60	44	67	6	24	7	30	31.5	2-M6	14-15
	22<d1.d2≤28		48								
LK24-CC70-□□□-□□□WP	18≤d1.d2≤25	70	47	72.6	7.3	25	8	36	38	2-M6	14-15
	25<d1.d2≤35		56								
LK24-CC80-□□□-□□□WP	22≤d1.d2≤25	80	53	87.2	9	30	9.2	36	42	2-M8	30-35
	25<d1.d2≤35		70								
LK24-CC90-□□□-□□□WP	25≤d1.d2≤32	90	66	88	10	30	8	43	43	2-M8	30-35
	32<d1.d2≤42		74								
LK24-CC100-□□□-□□□WP	32≤d1.d2≤48	100	84	112	11	40	10	56	50	2-M10	65-68
LK24-CC128-□□□-□□□WP	32≤d1.d2≤45	128	88	116	12	40	12	62	60	2-M12	100-110
	45<d1.d2≤60		105								
LK24-CC148-□□□-□□□WP	50≤d1.d2≤80	148	128	143	13	50	17	81	70	2-M12	100-110

说明:

- 1.对于上表以外的孔径,如需定货,可另行提供服务,请向本公司洽询。
- 2.对方安装轴公差为h7,h8级,如轴公差为其他公差,请提供公差要求由厂家定做。

Note:

1. For other bore sizes which are not listed above, customized ones are available, please consult us.
2. Standard bore tolerance is for the shaft with tolerance h7 or h8, if other tolerance is required, please consult us.

COUP-LINK®

## 标准孔径 Standard Bore Diameter

单位 (unit):mm

型号 Model	标准孔径 Standard Bore Diameter · d1·d2 (mm)																									
	12	14	15	16	18	19	20	22	24	25	28	30	32	35	38	40	42	45	48	50	55	60	65	70	75	80
LK24-CC60-□□□-□□□WP	•	•	•	•	•	•	•	•	•	•	•															
LK24-CC70-□□□-□□□WP					•	•	•	•	•	•	•	•	•													
LK24-CC80-□□□-□□□WP								•	•	•	•	•	•													
LK24-CC90-□□□-□□□WP									•	•	•	•	•	•	•	•										
LK24-CC100-□□□-□□□WP													•	•	•	•	•	•	•							
LK24-CC128-□□□-□□□WP													•	•	•	•	•	•	•	•	•	•				
LK24-CC148-□□□-□□□WP																				•	•	•	•	•	•	•

## 技术参数 Specifications

单位 (unit): mm

型号 Model	额定扭矩 Rated Torque (N.m)	最高转速 Max. Rotational Frequency (rpm)	惯性力矩 Moment of Inertia (Kg.m <sup>2</sup> )	静态扭矩刚性 Static Torsional Stiffness (N.m/rad)	容许径向偏差 Errors of Eccentricity (mm)	容许角向偏差 Errors of Angularity (°)	容许轴向偏差 Errors of shaft End-play (mm)	重量 N.W. (g)
LK24-CC60-□□□-□□□WP	60	14000	$2.84 \times 10^{-4}$	53000	0.2	2	±0.6	594
LK24-CC70-□□□-□□□WP	100	14000	$5.96 \times 10^{-4}$	120000	0.25	2	±1.0	878
LK24-CC80-□□□-□□□WP	200	13000	$1.53 \times 10^{-3}$	156000	0.32	2	±1.0	1778
LK24-CC90-□□□-□□□WP	300	12000	$2.23 \times 10^{-3}$	261000	0.32	2	±1.2	2069
LK24-CC100-□□□-□□□WP	450	10000	$4.23 \times 10^{-3}$	370000	0.38	2	±1.3	3153
LK24-CC128-□□□-□□□WP	600	9000	$1.14 \times 10^{-2}$	485000	0.38	2	±1.6	5480
LK24-CC148-□□□-□□□WP	800	8000	$2.85 \times 10^{-2}$	620000	0.38	2	±1.8	9263

说明:

1. 惯性力矩和重量按最大孔径计算。
2. 扭矩刚性为单个元件的实测值。
3. 最高转速未考虑动平衡。

Note:

1. Moment of inertia and mass figures based on the maximum shaft bores.
2. Torque rigidity is the measured value of a single element.
3. The maximum speed does not consider dynamic balance.

COUP-LINK®

**LK24 系列** 选项: 适用键槽轴, 键槽尺寸

LK24 Series Clamp Keyway Type ( Double Spring Plates )

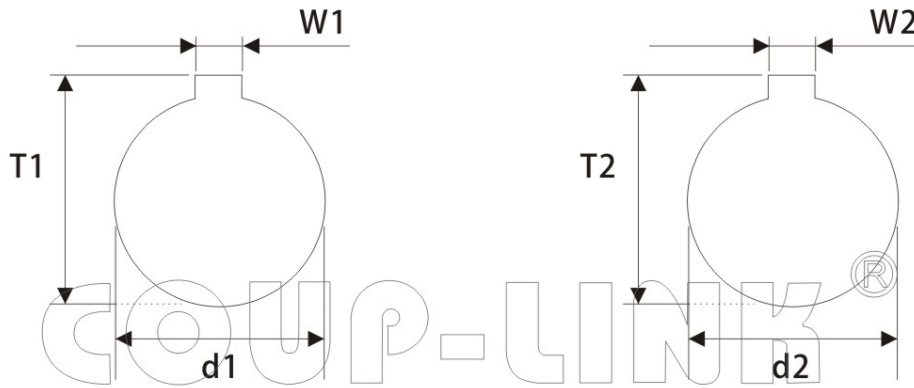

单位 (unit): mm

**键槽标准尺寸表(国标JS9): Standard Dimension Table of Keyway(Js9)**

孔径 φd1 φd2 Bore	键槽宽度 Keyway W1.W2 (mm)	键槽高度 Keyway T1.T2 (mm)	孔径 φd1 φd2 Bore	键槽宽度 Keyway W1.W2 (mm)	键槽高度 Keyway T1.T2 (mm)
6	2	7	32	10	35.3
8	2	9	35	10	38.3
9	3	10.4	38	10	41.3
10	3	11.4	40	12	43.3
11	4	12.8	42	12	45.3
12	4	13.8	45	14	48.8
13	5	15.3	48	14	51.8
14	5	16.3	50	14	53.8
15	5	17.3	55	16	59.3
16	5	18.3	56	16	60.3
17	5	19.3	60	18	64.4
18	6	20.8	65	18	69.4
19	6	21.8	70	20	74.9
20	6	22.8	75	20	79.9
22	6	24.8	80	22	85.4
24	8	27.3	85	22	90.4
25	8	28.3	90	25	95.4
28	8	31.3	95	25	100.4
30	8	33.3	100	28	106.4

## 选型举例：Ordering Information

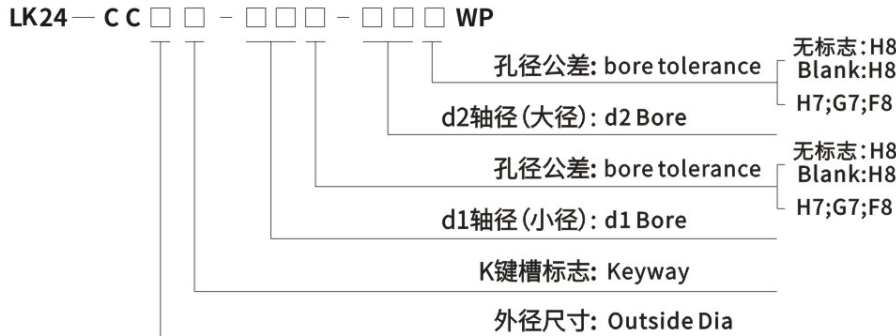

### 键槽说明:

两端孔都加键槽时,在联轴器外径后面加K表示,只有一端孔加键槽时,K加在要加键槽那端孔的公差后面,前面外径后不用加K,非标键槽必须提供键槽图纸

### KEYWAY NOTE:

when both bores are with keyway, code "K" should be added after the outer diameter of the coupling. If only one bore is with keyway, code "K" should be added after the tolerance code of the relative bore size only (Do not add to the outer diameter). If any customized dimension required, please provide your drawings.

## 例: LK24-CC60K-20-24WP

LK24: 系列号, 材料为45#钢  
CC60: 外径尺寸: 60mm夹紧螺丝固定  
20: d1孔径为: 20mm,孔公差为H8  
24: d2孔径为: 24mm,孔公差为H8  
K: 表示20,24两孔都加标准键槽  
WP: 双膜片

### Example: LK24-CC60K-20K-24

LK24: Series NO, Material: C45 steel  
CC60: Outside Dia:60mm, Clamp Type  
20: d1 Bore: 20mm, H8  
24: d2 Bore: 24mm, H8  
K: 20, 24 bore standard keyway  
WP: Double plate springs

## 例: LK24-CC60-20K-24WP

LK24: 系列号, 材料为45#钢  
CC60: 外径尺寸: 60mm夹紧螺丝固定  
20: d1孔径为: 20mm,孔公差为H8  
24: d2孔径为: 24mm,孔公差为H8  
K: 表示20端孔加标准键槽

### Example: LK24-CC60-20K-24WP

LK24: Series NO, Material: C45 steel  
CC60: Outside Dia:60mm, Clamp Type  
20: d1 Bore: 20mm, H8  
24: d2 Bore: 24mm, H8  
K: 20 bore standard keyway