

LK5 系列

LK5 Series

使用注意事项:

CAUTIONS:

1. 请务必遵守偏心, 偏角, 轴向的允许公差。
2. 螺栓类请务必以指定的扭矩拧紧。
3. 联轴器左右内径的同心度通过使用专用夹具实现高精度组装。万一联轴器受到强烈冲击时,可能会无法保持组装精度而在使用中发生破损,请在操作过程中加以留意。
4. 使用环境范围为-30°C-120°C。虽具备耐水性和耐油性,但极度粘附的环境也会导致产品劣化,请避免此类情况。
5. 弹性元件由薄薄的不锈钢膜片组成,使用时注意避免划伤。
6. 插入安装轴前,请勿拧紧夹紧螺栓。

1. Be sure to observe allowable tolerances of eccentricity, deflection and axis.
2. Bolts must be tightened with specified torque.
3. The concentricity of the left and right inner diameters of the coupling can be assembled accurately by using special fixtures. In case of strong impact on the coupling, the assembly accuracy may not be maintained and the coupling may be damaged in use, please pay attention to it during operation.
4. The use range is - 30°C - 120°C. Despite water and oil resistance, extreme adhesion can also lead to deterioration of the product, avoid this kind of situation.
5. Plate springs consist of thin stainless steel diaphragms, when using, care should be taken to avoid scratches.
6. Do not tighten the clamping bolt before inserting the installation shaft.

安装方式:

INSTALLATION:

1. 确认联轴器的夹紧螺栓有无松动, 去除轴及联轴器内径面的锈迹, 灰尘及油等。特别是, 对联轴器摩擦系数有显著影响的各类润滑脂, 绝不可有粘附。

Confirm whether the clamping bolt of the coupling is loose or not, remove rust, dust and oil on the inner diameter surface of the shaft and coupling. In particular, all kinds of greases which have a significant impact on the friction coefficient of the coupling must not have adhesion.

2. 请将联轴器插入电动机轴。插入时, 请勿在联轴器的弹性元件上施加过大的压缩和拉伸力, 特别是在把联轴器安装至电动机后将联轴器插入从动轴时, 可能会因错误操作而施加过大的压缩力, 请注意。

Please insert the coupling into the motor shaft. When inserting, do not apply excessive compression and tension force on the elastic components of the coupling, especially when inserting the coupling into the driven shaft after installing the coupling to the motor, excessive compression force may be exerted due to incorrect operation, please note.

3. 在2根夹紧螺栓处于松动状态下, 请确认联轴器是否能沿轴向和旋转方向轻微移动, 如果无法顺畅移动, 请重新调整两轴的定心。该方法推荐用作确认左右同心度的简易方法, 如果无法使用同样的确认方法, 请使用其他测量方法确认安装精度。

When the two clamping bolts are loose, make sure that the coupling can move slightly along the axis and rotation direction. If it can not move smoothly, please readjust the centering of the two axes. This method is recommended as a simple method to confirm the left and right concentricity. If the same method cannot be used, please use other measuring methods to confirm the installation accuracy.

LK5 系列

LK5 Series

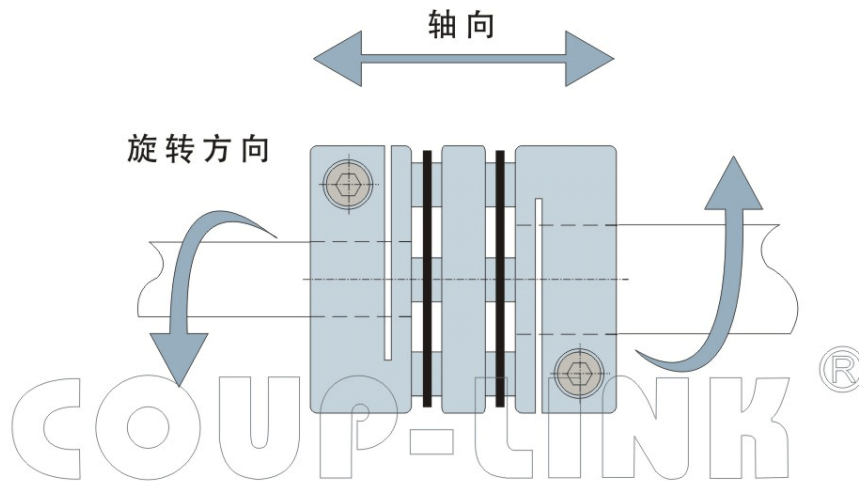

4.安装轴原则上为圆轴,当使用非圆轴时,请注意下图所示的安装位置。(请注意勿使键槽,D型切槽进入灰色部份一侧)
 轴安装位置不当可能会造成联轴发生破损,轴夹持力下降。为获得令人满意的联轴器性能,我们建议使用圆轴。
 Installation shaft is circular in principle. When using non-circular shaft, please pay attention to the installation position shown in the following figure. (Please pay attention not to make the keyway, D-groove into the grey part of the side), the improper installation of the shaft may cause damage to the coupling, reduce the shaft clamping force. In order to obtain satisfactory coupling performance, we recommend the use of circular shafts.

推荐安装方式:

RECOMMENDED INSTALLATION METHOD:

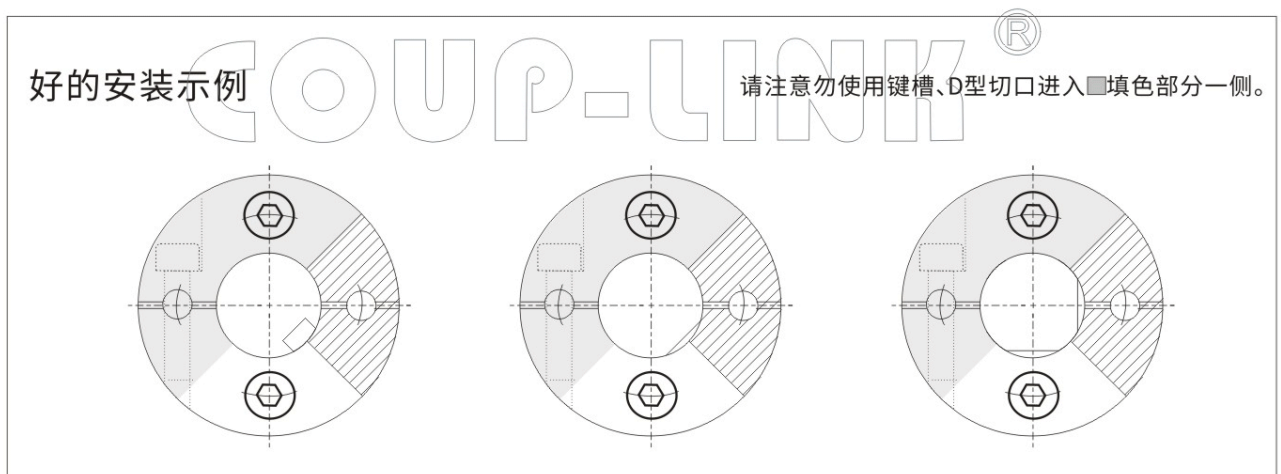

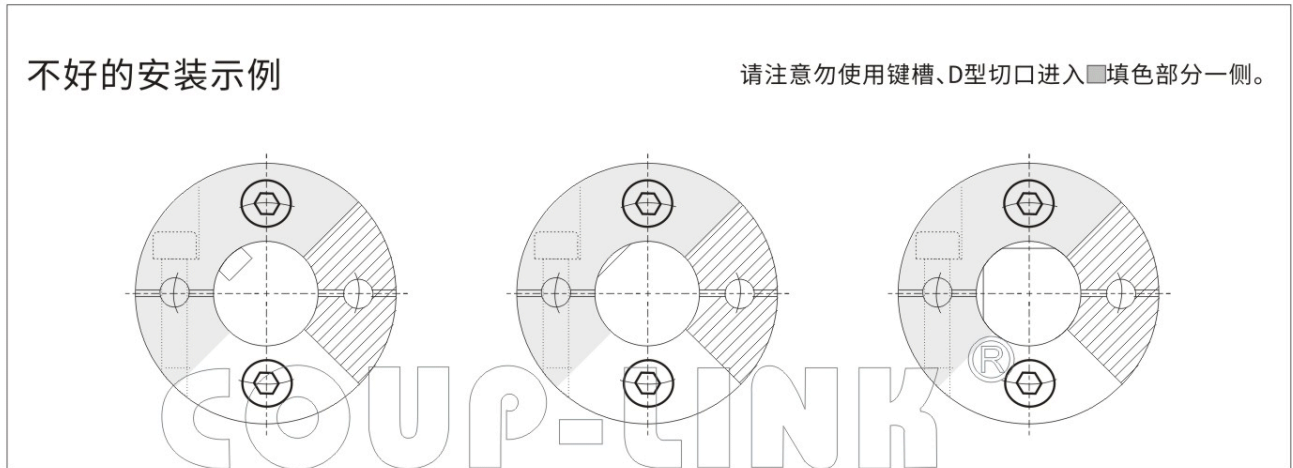
不推荐安装方式:**RINSTALLATION IS NOT RECOMMENDED:**

5. 两边轴插入联轴器的长度如下图所示, 使安装轴贯穿边节法兰全长 ($L1$ 尺寸), 且不得与弹性元件及另一边的轴干涉。请将夹紧法兰面到面尺寸 (W 尺寸) 控制在相对于标准值的轴向位移允许误差范围内。

该值为假设偏心, 偏角均为零时的允许值, 请尽量调小。

The length of the insertion couplings on both sides of the shaft is shown in the figure below, so that the installation shaft runs through the full length of the flange at the side section ($L1$ size) and does not interfere with the elastic element and the other side of the shaft. Please control the clamping flange face-to-face dimension (W dimension) within the allowable error range of axial displacement relative to the standard value. This value is the allowable value for assuming eccentricity and zero offset angle. Please adjust it as small as possible.

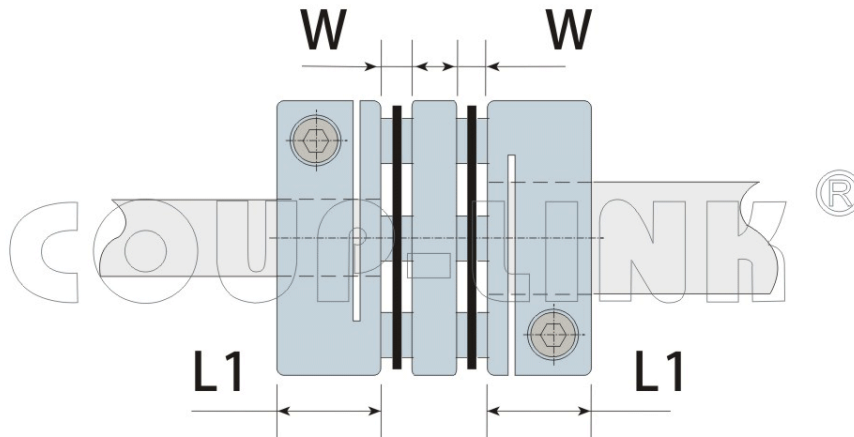

6. 确认轴向无压缩, 拉伸等作用力后, 请将两根夹紧螺栓拧紧。拧紧螺栓时, 请使用经过校准的扭力扳手, 并按技术参数表的拧紧扭矩拧紧。

Please tighten the two clamping bolts after confirming that there is no compression, tension and other forces in the axial direction. When tightening the bolt, please use the calibrated torsion plate hand and tighten the torque according to the technical parameter table.

7. 作为夹紧螺栓的初期防松措施, 建议运行一段时间后, 再次使用正确紧固扭矩进行再拧紧。

As an initial anti-loosening measure of clamping bolt, it is suggested that after running for a period of time, the correct tightening torque should be used again for tightening.

LK5 系列 III.多节夹紧螺丝固定式(膜片联轴器)

LK5 Series III.Clamp Type(Double Spring Plates)

特点 Features

- 高扭矩刚性和高灵敏度
 - 零回转间隙
 - 顺时针与逆时针回转特性完全相同
 - 不锈钢膜片补偿径向、角向和轴向偏差
 - 常用于伺服电机、步进电机联接
 - 夹紧螺丝固定
- High torque capacity and excellent response
 - Zero backlash
 - Identical clockwise and anticlockwise rotational characteristics
 - Stainless steel spring plates absorb angular misalignment and shaft end- play
 - For servo motor, step motor connection
 - Clamp type

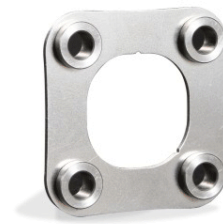
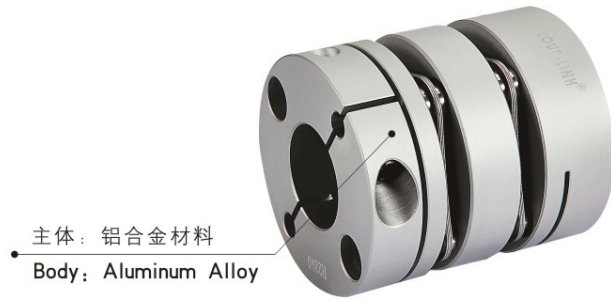

不锈钢一体化膜片组
LK5-C12WP~LK5-C104WP

选型举例: Ordering Information

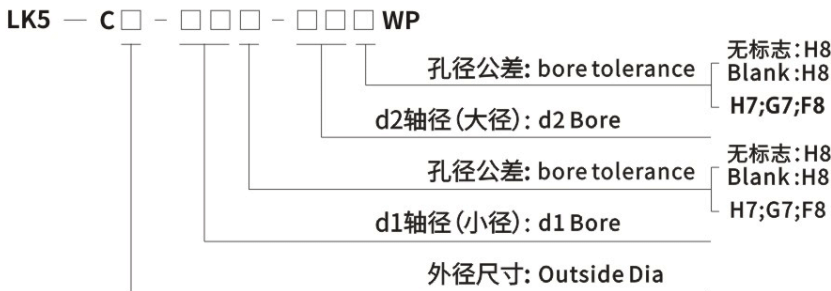

例:LK5-C56-20-24WP

LK5: 系列号, 材料为铝合金
C56: 外径尺寸: 56mm, 夹紧螺丝固定
20: d1孔径为: 20mm, 内孔公差为H8
24: d2孔径为: 24mm, 内孔公差为H8
WP: 双膜片

孔径公称请按照d1(小径)-d2(大径)的顺序标示

Example: LK5-C56-20-24WP

LK5: Series NO, Material: Aluminum Alloy
C56: Outside Dia: 56mm, Clamp Type
20: d1 Bore 20m, H8
24: d2 Bore 24m, H8
WP: Double spring plates

Please mark the bore diameter in the order of d1 (minor diameter) - d2 (major diameter)

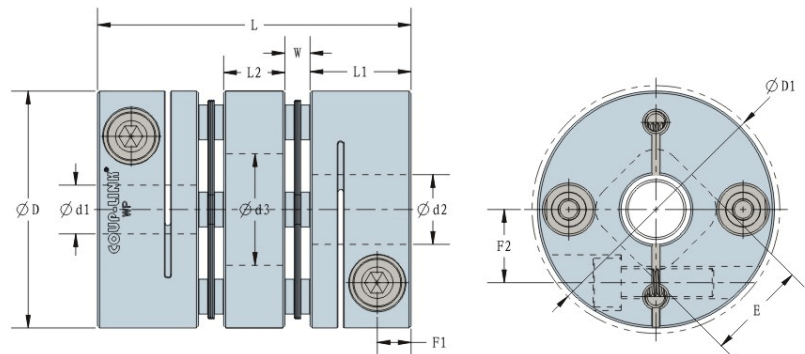

外型尺寸 Dimensions

单位 (unit): mm

型号 Model	d1 · d2		D	L	D1	W	L1	L2	F1	F2	d3	E	M	拧紧力矩 Tightening Torque (N·m)
	最小孔径 Min·Bore	最大孔径 Max·Bore												
LK5-C12-□□□-□□□WP	3	5	12	15.9	12.5	0.55	5.9	3.0	1.8	4	5.6	5.5	M1.6	0.23-0.28
LK5-C15-□□□-□□□WP	3	5	15	20	17	1.25	7.6	2.3	2.5	4.5	5.2	5.4	M2	0.4-0.5
LK5-C16-□□□-□□□WP	3	6	16	23	17	1.25	7.9	4.75	2.6	4.8	6.5	6.2	M2	0.4-0.5
LK5-C19-□□□-□□□WP	3	8	19.5	27.8	19.5	2.3	9.2	4.8	3.2	6	8.5	8.5	M2.5	1.0-1.1
LK5-C26-□□□-□□□WP	4	10	26	35	26	2.8	11.35	6.7	4	8	12.5	10.6	M3	1.5-1.9
LK5-C27-□□□-□□□WP	4	14	27	32.9	27.5	2.8	11	5.3	3.85	9.5	14.5	14.5	M3	1.5-1.9
LK5-C30-□□□-□□□WP	6	14	30	35	30	3.1	11.35	6.1	4	10	16	14.5	M3	1.5-1.9
LK5-C34S-□□□-□□□WP	6.35	14	34	41	34	3.6	13.4	7.0	4.8	10.5	16	14.5	M4	3.4-4.1
LK5-C34-□□□-□□□WP	6.35	14	34	45	34	3.6	14.5	8.8	4.8	10.5	16	14.5	M4	3.4-4.1
LK5-C39-□□□-□□□WP	8	16	39	49	39	4.5	15.0	10.0	5	12.5	17	17.1	M4	3.4-4.1
LK5-C44-□□□-□□□WP	9	19	44	50	44	4.8	15.0	10.4	5	15.5	20	20.5	M4	3.4-4.1
LK5-C50-□□□-□□□WP	10	22	50	57	50	5.5	17.5	11.0	5.75	18	24	23	M5	7.0-8.5
LK5-C56-□□□-□□□WP	11	24	56	63	56	5.5	20.0	12.0	6.9	21	28	26	M5	7.0-8.5
LK5-C62-□□□-□□□WP	14	30	62	69.5	62	3.0	24.0	15.5	7.55	22	31	30.5	M6	14-15
LK5-C68-□□□-□□□WP	14	35	68	74	68	6.0	24.0	14.0	7.55	25	36	31	M6	14-15
LK5-C82-□□□-□□□WP	18	38	82	98	82	8.0	30.0	22.0	9.4	29	41	38	M8	30-35
LK5-C94-□□□-□□□WP	25	40	94	98	94	8.5	30.0	21.0	9.9	33	41	41	M10	65-68
LK5-C104-□□□-□□□WP	35	45	104	102	104	10.0	30.0	22.0	9.9	38	46	45	M10	65-68

说明:

1. 对于上表以外的孔径, 如需定货, 可另行提供服务, 请向本公司洽询。

2. 对方安装轴公差为h7, h8级, 如轴公差为其他公差, 请提供公差要求由厂家定做。

Note:

1. For other bore sizes which are not listed above, customized ones are available, please consult us.

2. Standard bore tolerance is for the shaft with tolerance h7 or h8, if other tolerance is required, please consult us.

标准孔径 Standard Bore Diameter

单位 (unit): mm

型号 Model	标准孔径 Standard Bore Diameter · d1·d2 (mm)																													
	3	4	5	6	6.35	7	8	9	9.525	10	11	12	14	15	16	18	19	20	22	24	25	28	30	32	35	38	40	42	45	
LK5-C12-□□□-□□□WP	•	•	•																											
LK5-C15-□□□-□□□WP	•	•	•																											
LK5-C16-□□□-□□□WP	•	•	•	•																										
LK5-C19-□□□-□□□WP	•	•	•	•	•		•	•	•																					
LK5-C26-□□□-□□□WP		•	•	•	•	•	•	•	•	•	•																			
LK5-C27-□□□-□□□WP		•	•	•	•	•	•	•	•	•	•	•	•																	
LK5-C30-□□□-□□□WP			•	•	•	•	•	•	•	•	•	•	•	•																
LK5-C34S-□□□-□□□WP			•	•	•	•	•	•	•	•	•	•	•	•																
LK5-C34-□□□-□□□WP			•	•	•	•	•	•	•	•	•	•	•	•																
LK5-C39-□□□-□□□WP							•	•	•	•	•	•	•	•	•															
LK5-C44-□□□-□□□WP							•	•	•	•	•	•	•	•	•	•	•													
LK5-C50-□□□-□□□WP										•	•	•	•	•	•	•	•	•	•	•										
LK5-C56-□□□-□□□WP											•	•	•	•	•	•	•	•	•	•	•									
LK5-C62-□□□-□□□WP												•	•	•	•	•	•	•	•	•	•	•	•							
LK5-C68-□□□-□□□WP												•	•	•	•	•	•	•	•	•	•	•	•	•	•	•				
LK5-C82-□□□-□□□WP																•	•	•	•	•	•	•	•	•	•	•	•	•		
LK5-C94-□□□-□□□WP																					•	•	•	•	•	•	•	•	•	
LK5-C104-□□□-□□□WP																										•	•	•	•	•

COUP-LINK®

技术参数 Specifications

单位 (unit): mm

型号 Model	额定扭矩 Rated Torque (N.m)	最高转速 Max. Rotational Frequency (rpm)	转动惯量 Moment of Inertia (Kg.m ²)	静态扭矩刚性 Static Torsional Stiffness (N.m / rad)	容许径向偏差 Errors of Eccentricity (mm)	容许角向偏差 Errors of Angularity (°)	容许轴向偏差 Errors of shaft End-play (mm)	重量 N.W. (g)
LK5-C12-□□□-□□□WP	0.25	10000	7.67×10^{-8}	133	0.03	1	±0.08	3.7
LK5-C15-□□□-□□□WP	0.6	10000	3.45×10^{-7}	196	0.04	1	±0.1	7
LK5-C16-□□□-□□□WP	0.6	10000	3.58×10^{-7}	255	0.05	1	±0.1	10
LK5-C19-□□□-□□□WP	1.0	10000	9.1×10^{-7}	700	0.11	2	±0.2	17
LK5-C26-□□□-□□□WP	2.0	10000	3.61×10^{-6}	1850	0.15	2	±0.33	37
LK5-C27-□□□-□□□WP	2.2	10000	4.4×10^{-6}	2200	0.15	2	±0.33	40
LK5-C30-□□□-□□□WP	4.0	10000	6.18×10^{-6}	2850	0.16	2	±0.38	46
LK5-C34S-□□□-□□□WP	5.0	10000	1.19×10^{-5}	4050	0.18	2	±0.4	72
LK5-C34-□□□-□□□WP	5.0	10000	1.33×10^{-5}	4050	0.18	2	±0.4	80
LK5-C39-□□□-□□□WP	10	10000	2.58×10^{-5}	9000	0.24	2	±0.5	118
LK5-C44-□□□-□□□WP	12	10000	4.23×10^{-5}	10000	0.24	2	±0.6	150
LK5-C50-□□□-□□□WP	15	10000	8.18×10^{-5}	13000	0.26	2	±0.7	222
LK5-C56-□□□-□□□WP	25	10000	1.41×10^{-4}	16000	0.28	2	±0.8	307
LK5-C62-□□□-□□□WP	40	10000	2.52×10^{-4}	25000	0.31	2	±0.84	431
LK5-C68-□□□-□□□WP	60	10000	3.57×10^{-4}	35000	0.34	2	±0.9	499
LK5-C82-□□□-□□□WP	100	10000	1.02×10^{-3}	45000	0.52	2	±1.1	1004
LK5-C94-□□□-□□□WP	180	10000	1.79×10^{-3}	50000	0.52	2	±1.3	1400
LK5-C104-□□□-□□□WP	250	10000	2.76×10^{-3}	60000	0.55	2	±1.5	1765

说明:

1. 惯性力矩和重量按最大孔径计算。
2. 扭矩刚性为单个元件的实测性。
3. 最高转速未考虑动平衡。

Note:

1. Moment of inertia and mass figures based on the maximum shaft bores
2. Number of Torsional Elasticity as a Single Element
3. The maximum speed does not consider dynamic balance.

LK5 系列

LK5 Series

选项: 适用键槽轴, 键槽尺寸

Clamp Keyway Type (Double Spring Plates)

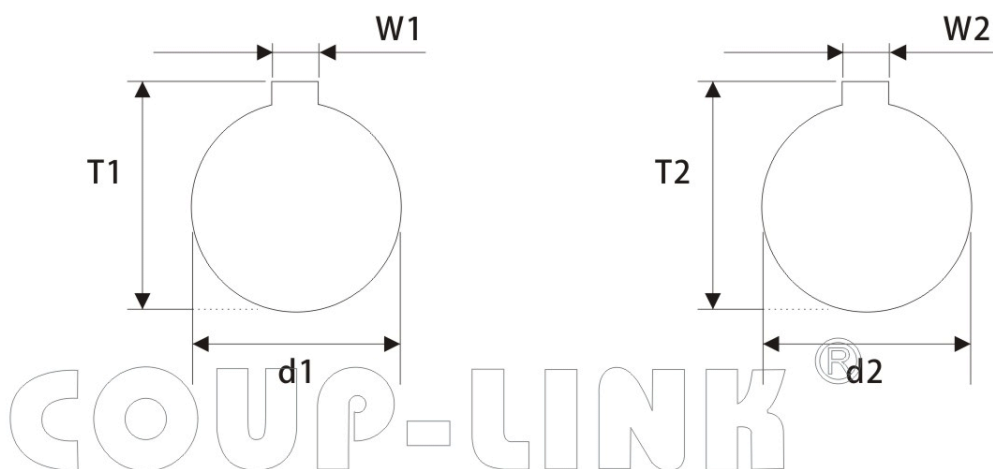

单位 (unit): mm

键槽标准尺寸表(国标JS9): Standard Dimension Table of Keyway(JS9)

孔径 φd1 φd2 Bore	键槽宽度 Keyway W1.W2 (mm)	键槽高度 Keyway T1.T2 (mm)	孔径 φd1 φd2 Bore	键槽宽度 Keyway W1.W2 (mm)	键槽高度 Keyway T1.T2 (mm)
6	2	7	32	10	35.3
8	2	9	35	10	38.3
9	3	10.4	38	10	41.3
10	3	11.4	40	12	43.3
11	4	12.8	42	12	45.3
12	4	13.8	45	14	48.8
13	5	15.3	48	14	51.8
14	5	16.3	50	14	53.8
15	5	17.3	55	16	59.3
16	5	18.3	56	16	60.3
17	5	19.3	60	18	64.4
18	6	20.8	65	18	69.4
19	6	21.8	70	20	74.9
20	6	22.8	75	20	79.9
22	6	24.8	80	22	85.4
24	8	27.3	85	22	90.4
25	8	28.3	90	25	95.4
28	8	31.3	95	25	100.4
30	8	33.3	100	28	106.4

选型举例：Ordering Information

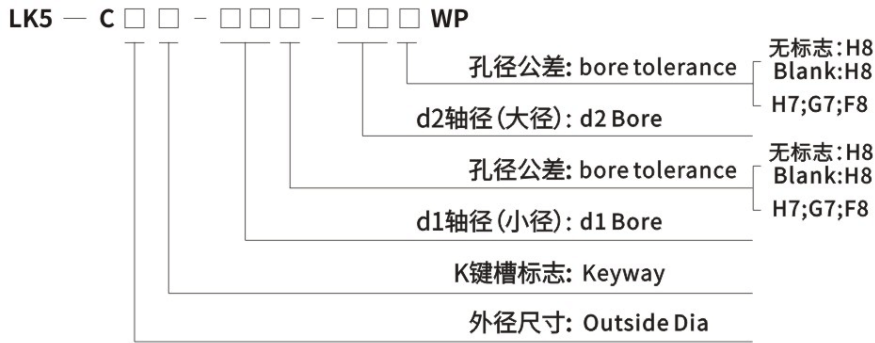

键槽说明:

两端孔都加键槽时,在联轴器外径后面加K表示,只有一端孔加键槽时,K加在要加键槽那端孔的公差后面,前面外径后不用加K,非标键槽必须提供键槽图纸

KEYWAY NOTE:

when both bores are keyed, K is added after the outer diameter of the coupling.

When only one bore is keyed, K is added after the tolerance of the bore of the keyway.

No K is added after the front outer diameter. The non-standard keyway must provide keyway drawings.

例: LK5-C34K-10-14WP

LK5: 系列号, 材料为铝合金

C34: 外径尺寸: 34mm夹紧螺丝固定

10: d1孔径为: 10mm,公差为H8

14: d2孔径为: 14mm,公差为H8

K: 表示10,14两孔都加标准键槽

WP: 双膜片

Example: LK5-C34K-10-14WP

LK5: Series NO, Material :Aluminum alloy

C34: Outside Dia:34mm,Clamp Type

10: d1 Bore: 10mm,H8

14: d2 Bore: 14mm,H8

K: 10,14 bore standard keyway

WP: Double spring plates

例: LK5-C34-10K-14WP

LK5: 系列号, 材料为铝合金

C34: 外径尺寸: 34mm夹紧螺丝固定

10: d1孔径为: 10mm,公差为H8

14: d2孔径为: 14mm,公差为H8

K: 表示10端孔加标准键槽

Example: LK5-C34-10K-14WP

LK5: Series NO, Material: Aluminum alloy

C34: Outside Dia:34mm,Clamp Type

10: d1 Bore: 10mm,H8

14: d2 Bore: 14mm,H8

K: 10 bore standard keyway